

Sistemi di Elaborazione dell'Informazione: Complementi di Gestione di Rete

Prima Parte:
Paradigmi e Protocolli per la Gestione di Rete

Anno Accademico 2008/2009

1. Introduction

1. Introduction

1.1 Motivation

1.2 Terminology and Basic Concepts

1.3 Abstract Syntax Notation One

2. Internet Management

1.1 Motivation: Why Do We Need Management ?

- ❑ Current situation:
 - ↳ increasing meaning of strategic resources "information".
 - ↳ a computer network is no longer only a supporting item in an enterprise, but takes even more frequently a key position.
 - ↳ the number of interconnected computers rose dramatically in the past few years. This process will probably continue to persist.
 - ↳ Complexity and functionality of the components grows in correspondence with the performance of the available hardware.

- ❑ Demand:
 - ↳ Permanent availability of network services with optimal quality.
 - ↳ Cost reduction for the network infrastructure of the company.

- ❑ Necessity:
 - ↳ computer-aided management of heterogeneous networks.

Subject of this Course

- ❑ Management implementation:
 - ↳ By humans (network administrators, operating surgeons), by special tools (hardware and software).
 - ↳ Hence network management is first of all an organisational problem.
 - ↳ Cost effective and flexible network guidelines and procedures need be compiled.
 - ↳ Tools and their technological bases are just aids to successful network management.

- ❑ Main Subjects:
 - ↳ Network management basics.
 - ↳ Architecture and functionality of network management
 - ↳ Open standards issued by independent organisations.

Network Management Dimensions

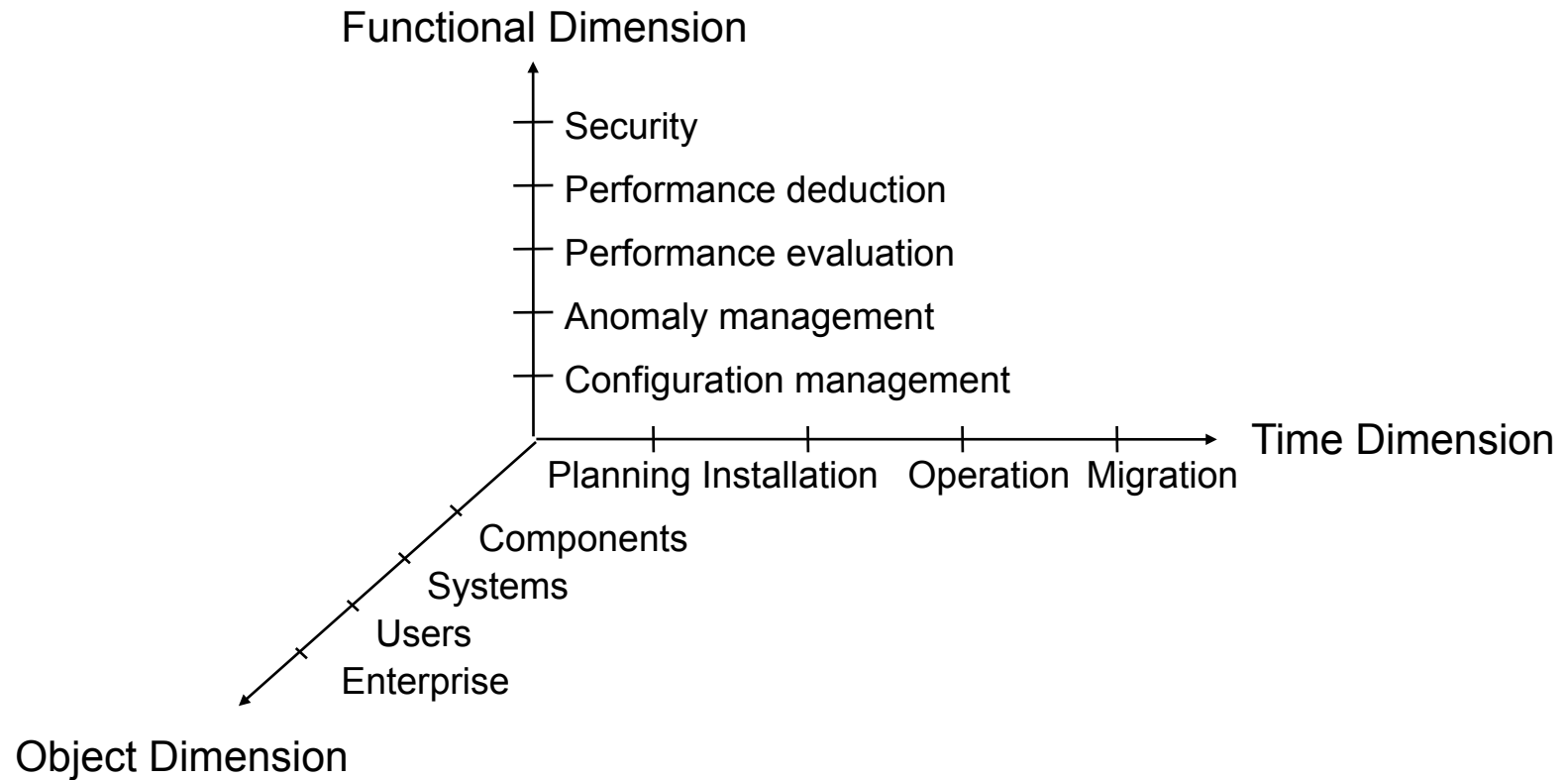

System Management Requirements [1/2]

- ❑ Guarantee the availability of the function on the net:
- ❑ Service maintenance (availability, response time) need to face with technological changes and big quota increase.
 - ↳ Security of the services through the control of security components.
 - ↳ (Human) Mistake prevention and bottleneck identification/recovery.
- ❑ Automatic or semiautomatic reaction on operation anomalies:
 - ↳ Real-time configuration modification in case of error.
 - ↳ Activation of redundant components in case of error.
- ❑ Dynamic reactions to changes on the network and environment:
 - ↳ Changes regarding applications, users, components, services or fees.
 - ↳ Dynamic adaptation of the available transmission bandwidth according to requests originated by the management system.

System Management Requirements [2/2]

- ❑ Network control:
 - ↳ Collection and (compressed) representation of relevant network information.
 - ↳ Definition and maintenance of a database of network configurations.
 - ↳ When applicable, centralization of the control over peripherals and implemented functions (central management console).
 - ↳ Integration of management procedures on heterogeneous environments

- ❑ Improvement of system/network administrators work conditions :
 - ↳ Improvement and standardization of the available tools
 - ↳ Identify and implement gradual automation of management functions.
 - ↳ Good integration of tools into the existing operational sequences.

- ❑ Progress through standardization :
 - ↳ Transition of existing, often proprietary, solutions in a standardized environment.

1.2 Terminology and Fundamental Concepts

- ❑ Control, co-ordination and monitoring of resources takes place via the manipulation from so-called managed objects:

"A *managed object* is the abstracted view of a resource that presents its properties as seen by (and for the purpose of) management." (ISO 7498-4)

- ❑ Managed objects are an abstract representation of a real resource.
- ❑ The boundary of a managed object specifies which details are accessible to a management system and which ones are shielded (black box).

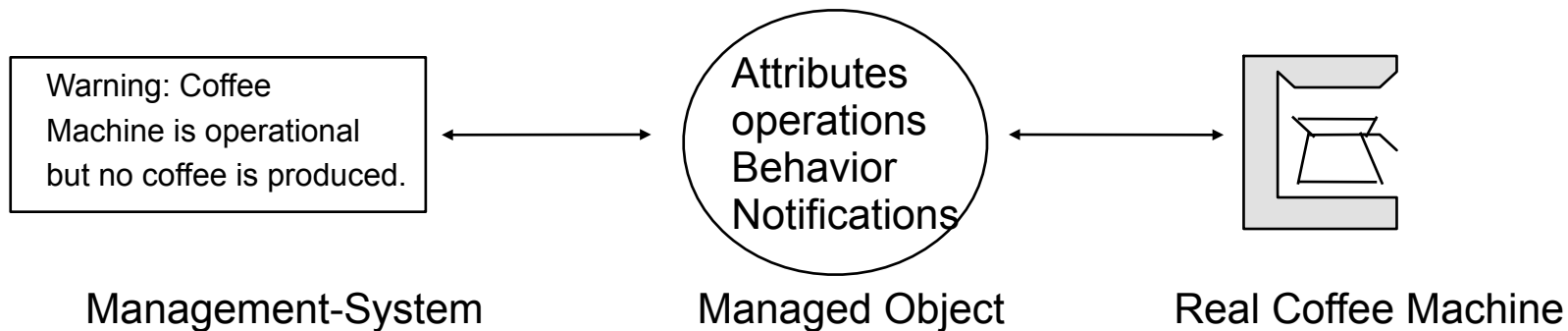

- Managed objects do not necessarily correspond to objects, as one knows from object-oriented programming. Simple variables correspond to the MOs in the Internet management.

Managed Objects (MO)

- ❑ Attributes:
 - ↳ Attributes describe the state/condition of managed objects.
 - ↳ Attributes can change when the condition of the real object changes.
 - ↳ Attributes can be manipulated by means of management operations.
- ❑ Operations:
 - ↳ Make it possible to access a managed object. Typical operations are get, set, create and delete.
 - ↳ The number and type of operations influence the object performance and complexity.
- ❑ Behavior:
 - ↳ Determines the semantics and interaction with the real resource.
 - ↳ The behavior of managed objects is normally defined in plain English.
- ❑ Notifications:
 - ↳ The quantity and type of the messages, which can be generated by pre-defined situations by a managed object when specific situations occur.

Management Information Base (MIB)

- ❑ The union of all managed objects contained in a system forms the *Management Information Base* (MIB) of the system:
 - "The set of managed objects within a system, together with their attributes, constitutes that system's management information base." (ISO 7498-4)
- ❑ This is the first interpretation of the term "Management Information Base" (more definitions will follow).

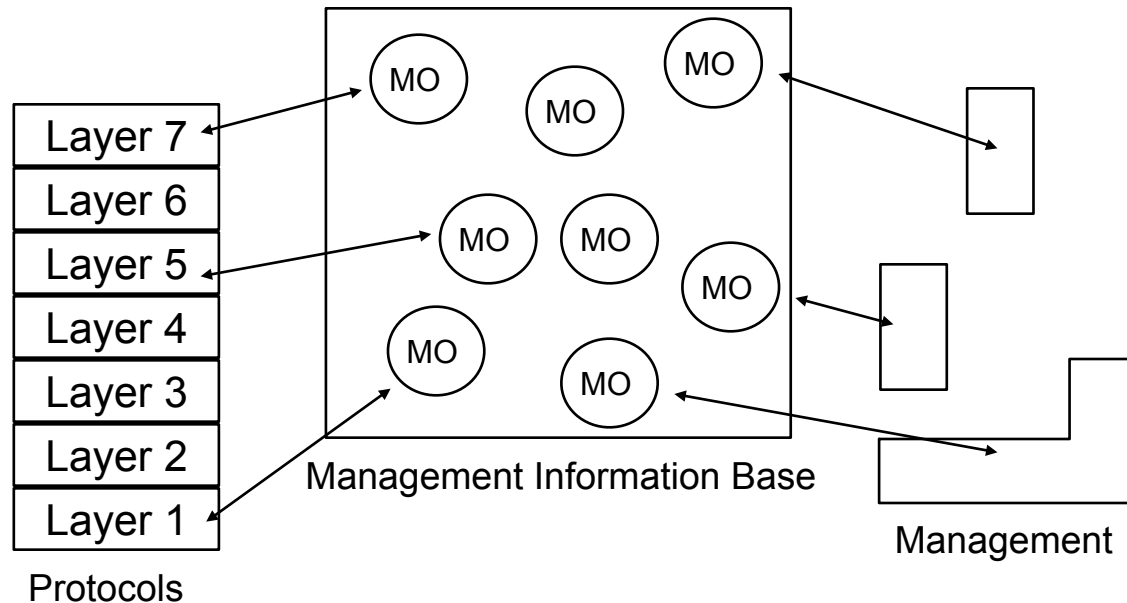

- ❑ A MIB should be known both to the implementer and the manager.

MIB Modularity

- ❑ Managed objects of a system are usually defined in multiple MIB definitions.

- ❑ Modules have been introduced in MIBs for enabling design modularity:
 - ↳ Different modules can be defined by different teams.
 - ↳ Management functionality can be gradually extended and modified.
 - ↳ Different systems can support different MIB modules/releases.
 - ↳ Vendors can extend the management functionality by means of proprietary MIBs.
 - ↳ MIBs are defined using a specification language

Manager/Agent Paradigm

- Agent:
 - ↳ Implements the MOs MIB by accessing the real resources.
 - ↳ Receives requests from a manager, processes them and transmits appropriate responses.
 - ↳ Dispatches notifications about important changes in status in the MIB.
 - ↳ Protects MOs against unauthorized accesses using access control rules and communication authentication with the partner.

- Manager:
 - ↳ Exercises control: it controls functions hence it is the crucial instance.
 - ↳ Starts up management operations by appropriate protocol operations for the manipulation of MOs.
 - ↳ Receives messages from agents and passes them on (for handling) to appropriate applications.

Management Protocol

- ❑ Management applications and MOs are not often on same node.
- ❑ A management protocol implements access to distant managed objects by encoding management data that is then secured during the transfer.

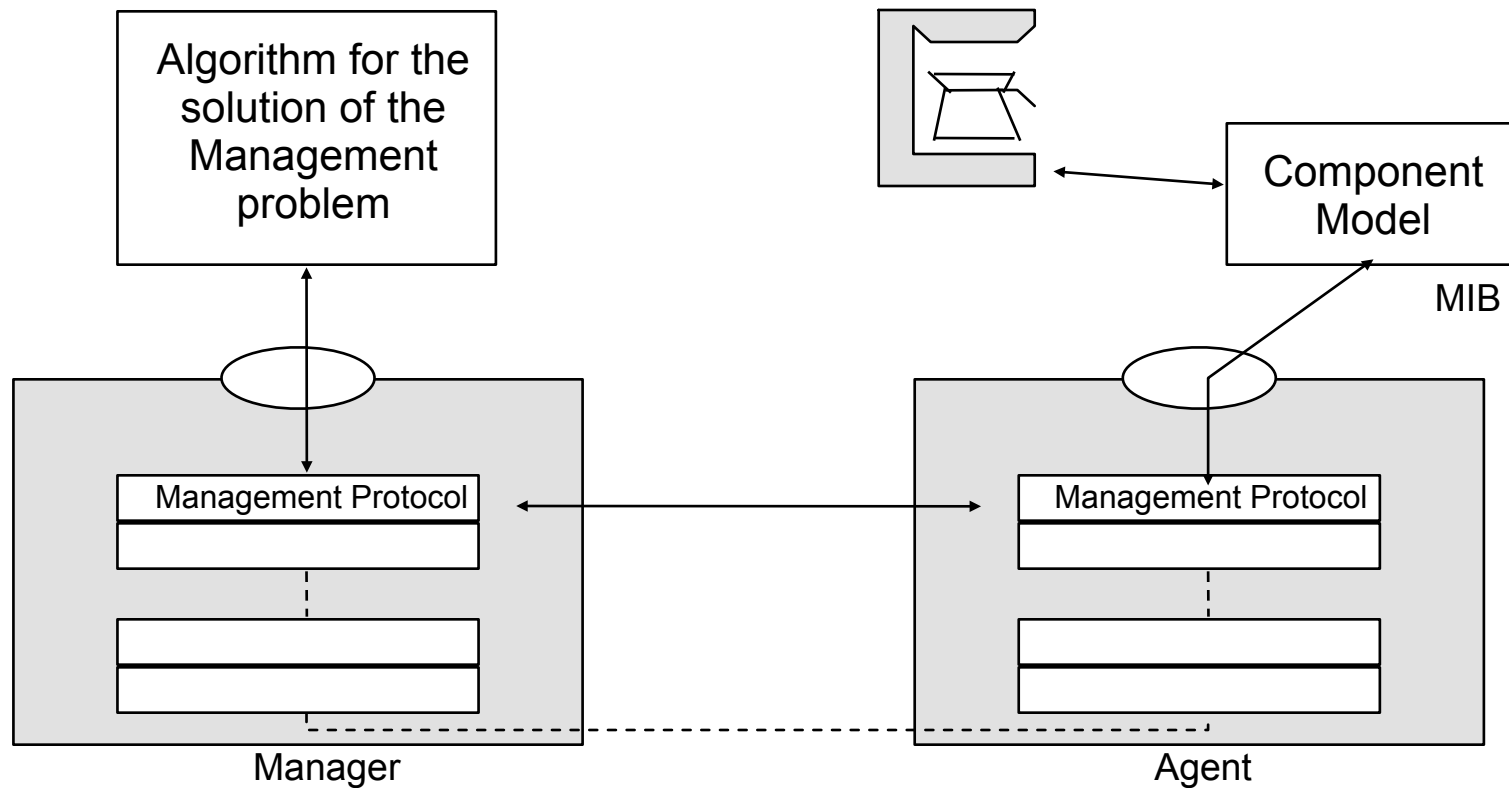

Functional Areas (FCAPS) [1/2]

- Management applications can be divided into 5 function areas:
 - ❑ Fault management:
 - ↳ Error detection, isolation, and repair.
 - ❑ Configuration management:
 - ↳ Production and administration of configuration information.
 - ↳ Name administration.
 - ↳ Start, check and termination of services.
 - ❑ Account management:
 - ↳ Entry of consumption (usage) data.
 - ↳ Distribution and monitoring of contingents.
 - ↳ Customer billing for resource consumption.

Functional Areas (FCAPS) [2/2]

- ❑ Performance management:
 - ↳ Statistic data collection.
 - ↳ Determination of the system performance.
 - ↳ Systems modifications for increase in efficiency.

- ❑ Security management:
 - ↳ Production and verification of security policies.
 - ↳ Generation and distribution of passwords and accounts.
 - ↳ Report and analysis of security-relevant events.

- These 5 functional areas according to the initial letters of the English terms normally under the contraction FCAPS.
- These functional areas are not mutually independent (data measurement has often impact on system configuration).
- Basic functions (e.g. monitoring of a counter for threshold values) often reside in different functional areas.

Management Architectures Overview

- Structure of the management information:
 - ↳ defines the rules of the description of Managed Objects.
 - Identification and designation of Mos.
 - Composition of MOs.
 - Behaviour of MOs.
 - Relations to other MOs.
 - Possible operations and internal messages of the MOs.
 - ↳ Definition of the datatypes, structure and syntax for the description of the MOs.
 - ↳ The quantity of the descriptions of MOs in accordance with these rules defines the *Management Information Base* (MIB)

- Management Protocols and Services:
 - ↳ Defines the services and enable the access to remote MOs.
 - ↳ Several protocols can be used for the implementation of the defined services.
 - ↳ The service primitive and the appropriate protocol operations influence considerably the efficiency and the complexity of the management system.

Management Architectures Overview

- Organisational Model:
 - ↳ Definition of the distribution of roles of a management architecture.
 - co-operative management of similar systems.
 - systems belonging to different management authorities (hierarchical concept)
 - ↳ Partitioning in *Management Domains* according to different criteria

- Functional Model:
 - ↳ Analysis of the total function and partitioning into functional areas by means of generic auxiliary functions.
 - ↳ Definition of the auxiliary functions and their parameters.
 - ↳ Implementation using several MOs (management support objects)

Services and Protocols: Some Definitions

- ❑ Service

It is defined as an abstract function supplied by a network

- ❑ Service Primitive

The individual elementary functions are called service-primitives. Typical ISO/OSI services are:

- request Service Request
- indication Indication that a service was requested
- response Reaction of the service to a service request
- confirm Acknowledgement that a requested service was provided

- ❑ Service Access Point (SAP)

The interfaces over which the service primitive can be access as service access points.

- ❑ Entities

The services furnished by so-called instances.

- ❑ Protocol

The rules and the restrictions according to which instances interact with other instances.

Representation and Layering of Services

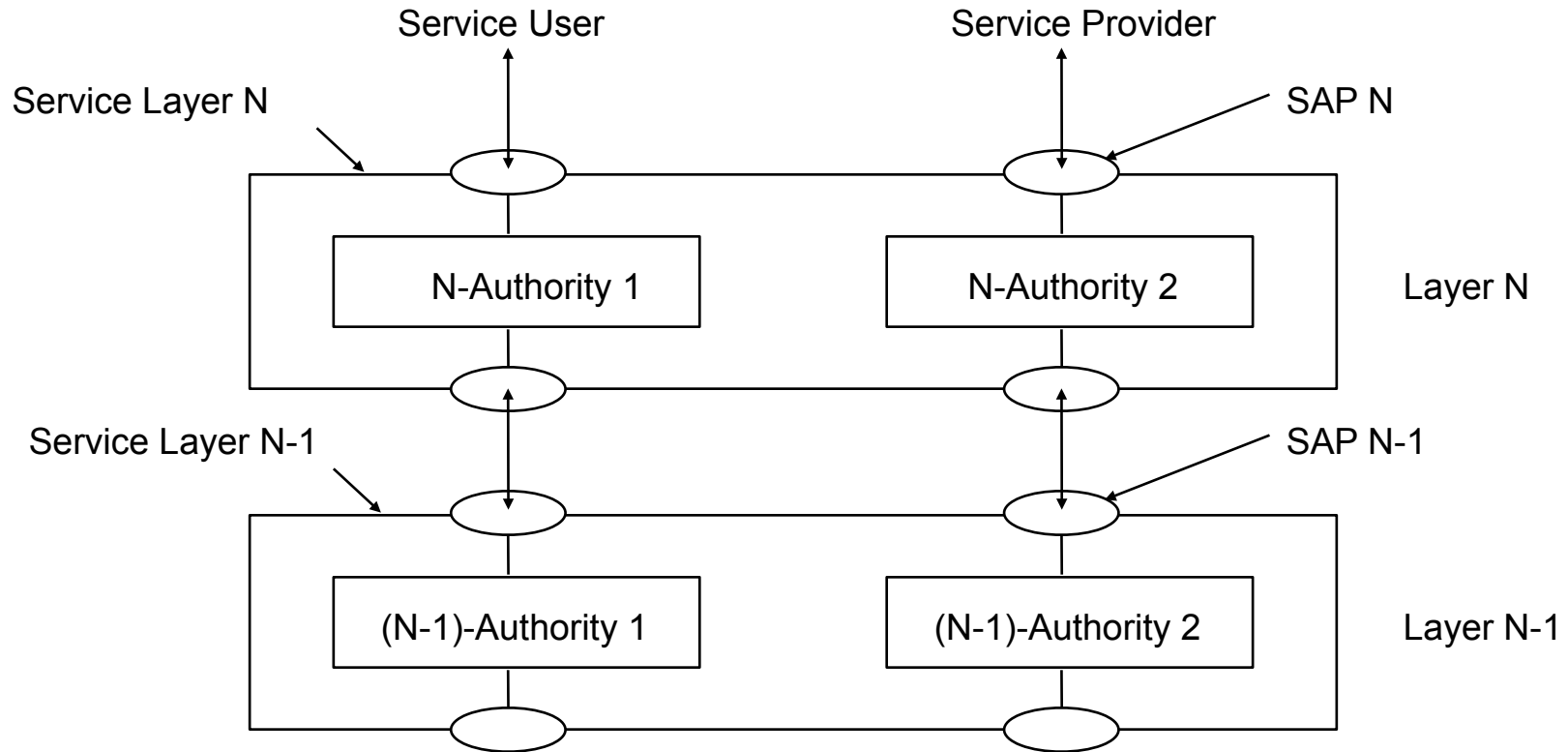

- ❑ The definition of layers is a fundamental principle for the structuring of communication systems.
- ❑ Services of a layer may only accept service primitives of services in adjacent layers.

Time Diagrams

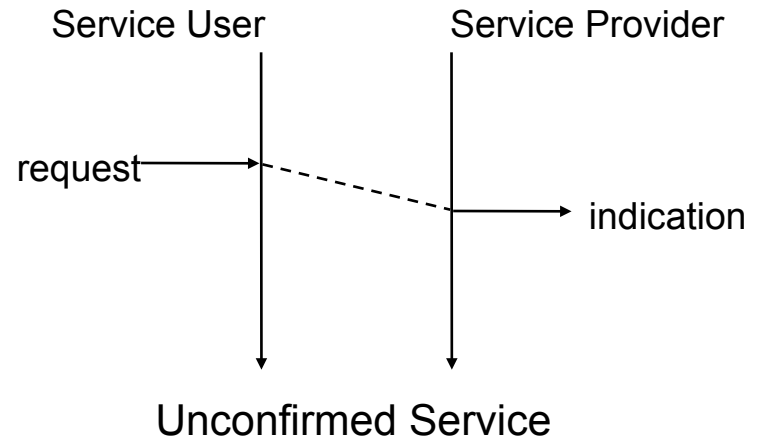
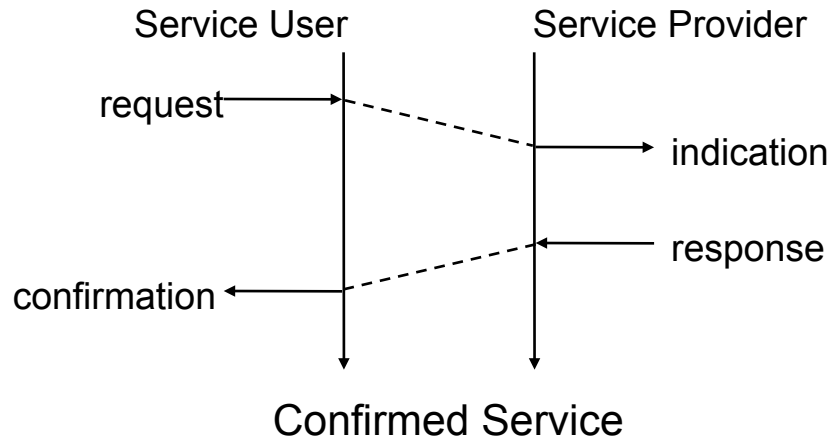

- ❑ Time diagrams clarify the temporal and spatial connections between service primitives.
- ❑ Vertical axis are time axis, horizontal axis give the spatial distance between users and providers of services.
- ❑ Service requests of a confirmed service can result either in a positive or negative confirmation.
- ❑ Service requests of an unconfirmed service are not acknowledged.

ISO/OSI-Reference Model

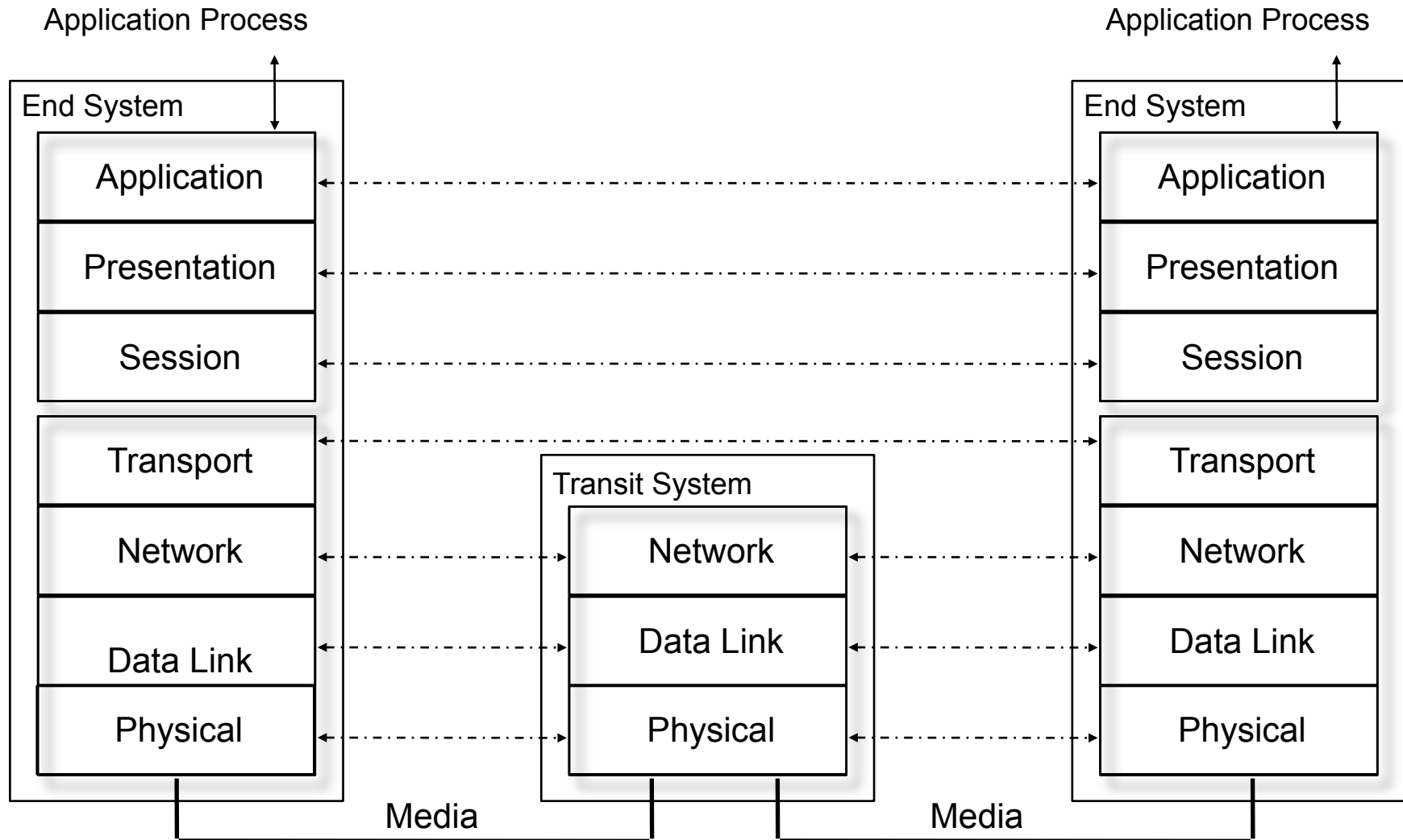

ISO/OSI Transport System [1/2]

□ Physical Layer

- ↳ Transport of a stream of bits over a media.
- ↳ Transport depending on the characteristics of the media being used.
- ↳ Representation of values 0 and 1 (e.g. voltage levels).
- ↳ Synchronisation between senders and recipients.
- ↳ Definition of standard plugs for media interconnection.

□ Data Link Layer

- ↳ Transport of a frame of bits.
- ↳ Data communication between systems that share a common media.
- ↳ Detection and recovery of transfer errors.
- ↳ Flow control for handling traffic peaks (traffic jam).
- ↳ Implementation usually in hardware on adapter cards (e.g. Ethernet card).

ISO/OSI Transport System [2/2]

- ❑ Network Layer
 - ↳ Determination of a route through the network (routing).
 - ↳ Multiplex of network connections over a shared connection.
 - ↳ Error detection and recovery between end-systems.
 - ↳ Flow control between end-systems.
 - ↳ Division of a Packet in multiple frames.

- ❑ Transport Layer
 - ↳ End-to-end communication between applications.
 - ↳ Virtual connections over connectionless datagram services.
 - ↳ Error detection and recovery between applications.
 - ↳ Flow control between applications.
 - ↳ Concurrent usage of multiple services.

ISO/OSI Higher Layers

- ❑ Session Layer
 - ↳ Synchronization and co-ordination of communicating processes.
 - ↳ Session control (checkpoints for recovery).

- ❑ Presentation Layer
 - ↳ Transformation and adaptation of data presentations (e.g ASCII EBCDIC).
 - ↳ Serialization of data structures for the purpose of transfer.
 - ↳ Data compression.

- ❑ Application Layer
 - ↳ Supply of fundamental services, which can be used directly by any application including (but not limited to):
 - ↳ File transfer, virtual terminals, name space administration, database access, network management, electronic communication networks, process and print control...

Internet Layer Model

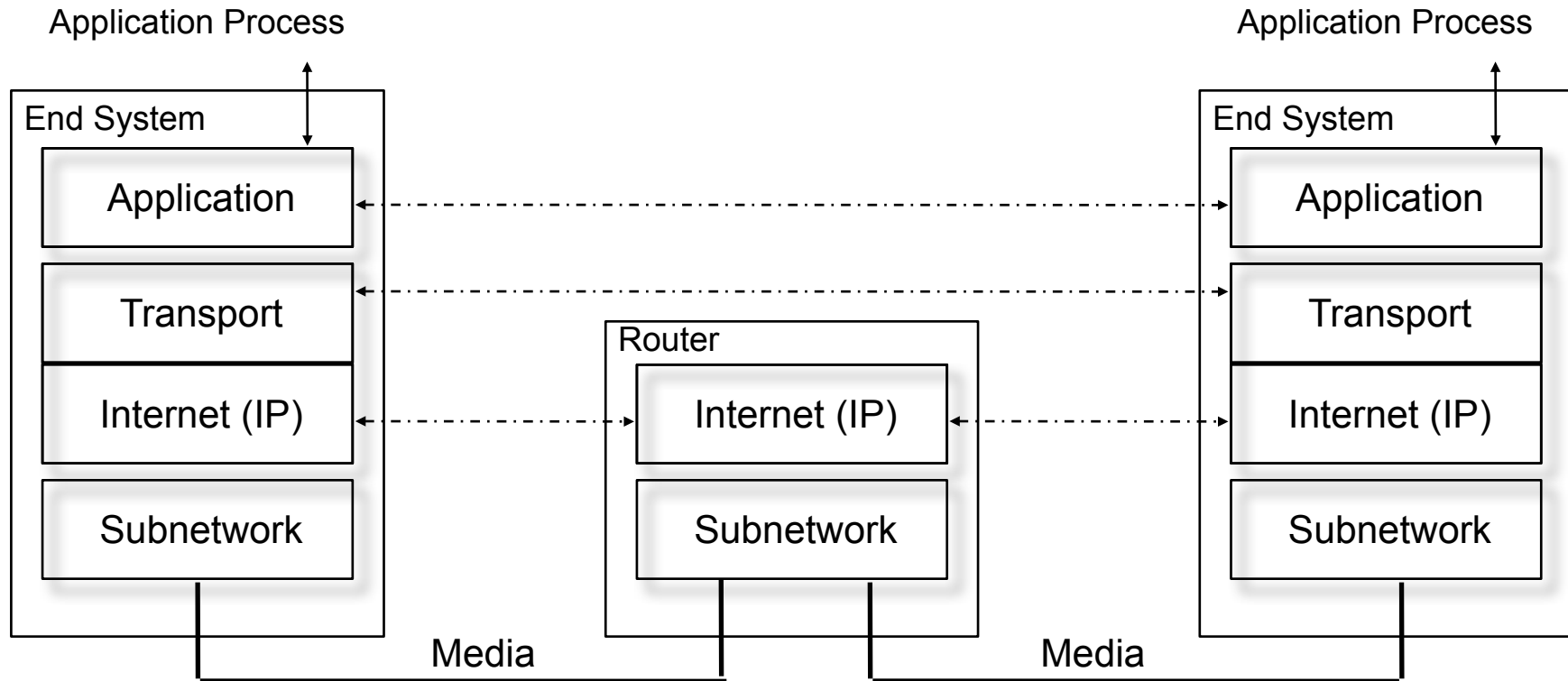

ISO Standardization

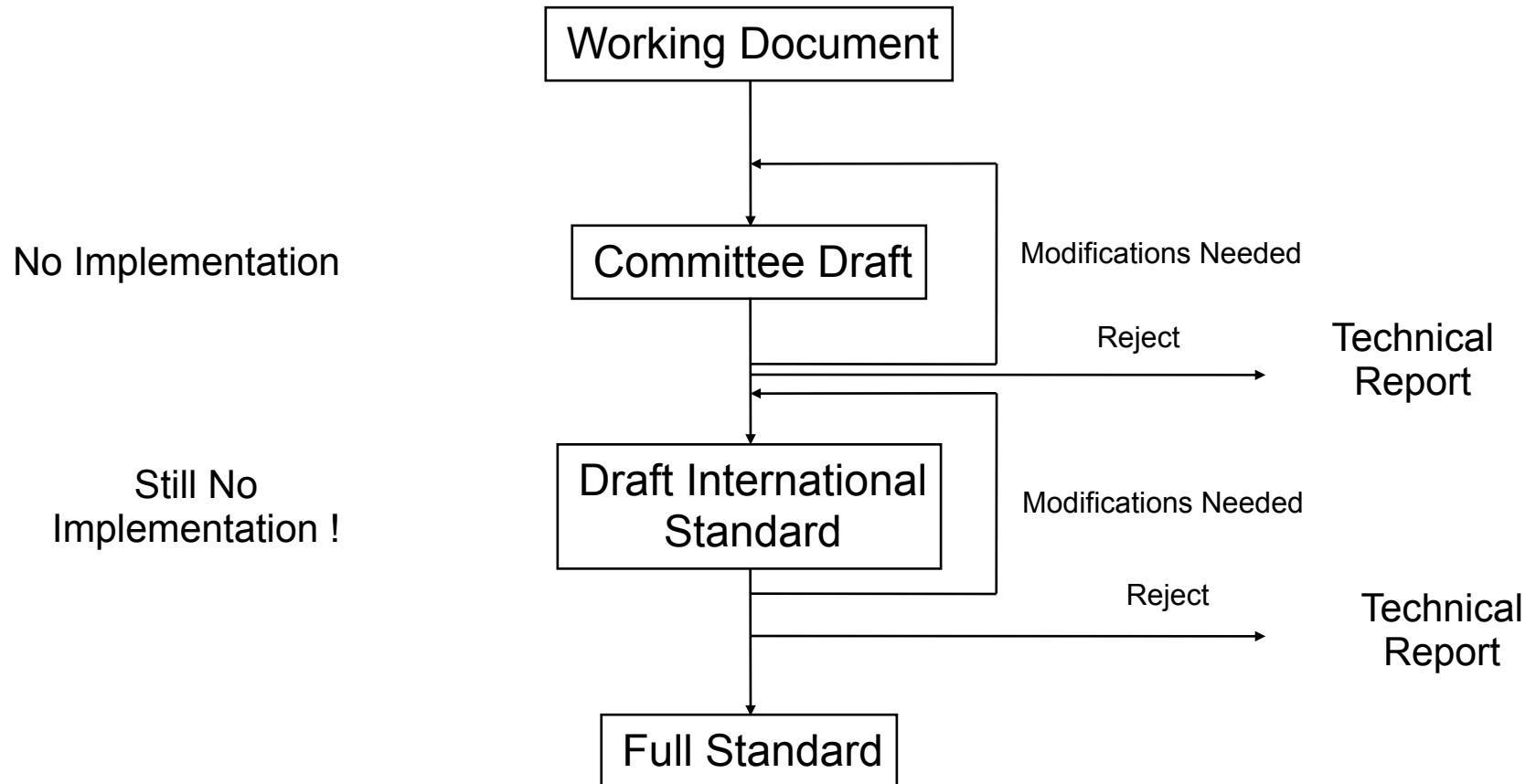

IETF Standardization

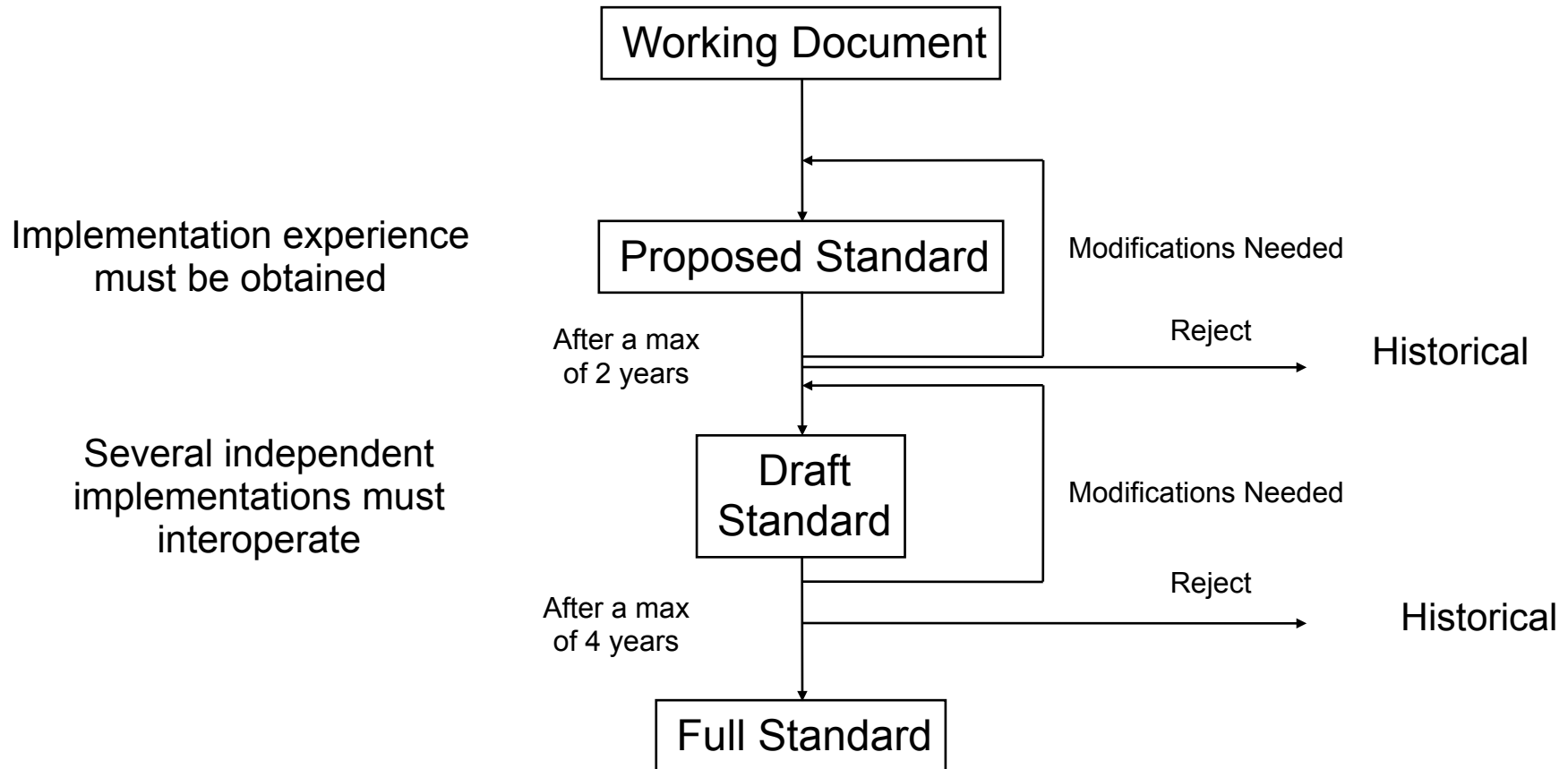

1.3 Overview: Abstract Syntax Notation One

- ❑ Abstract Syntax Notation One (ASN.1) is a syntax user for the definition of data structures and message formats.

- ❑ ASN.1 goals:
 - ↳ Exchange of information between machines with different hardware architectures (8/16/32/64 bit, little/big-endian).
 - ↳ Independence from existing programming languages (language neutral).
 - ↳ Coding of the data during the transfer should be selectable between senders and recipients (negotiation).

- ❑ Separation of the data presentation from the application-specific data structure representation.

- ❑ The abstract syntax defines the data structures during the transfer and determines in which form these data structures will serially transfer over a network.

Abstract Syntax and Transfer Syntax

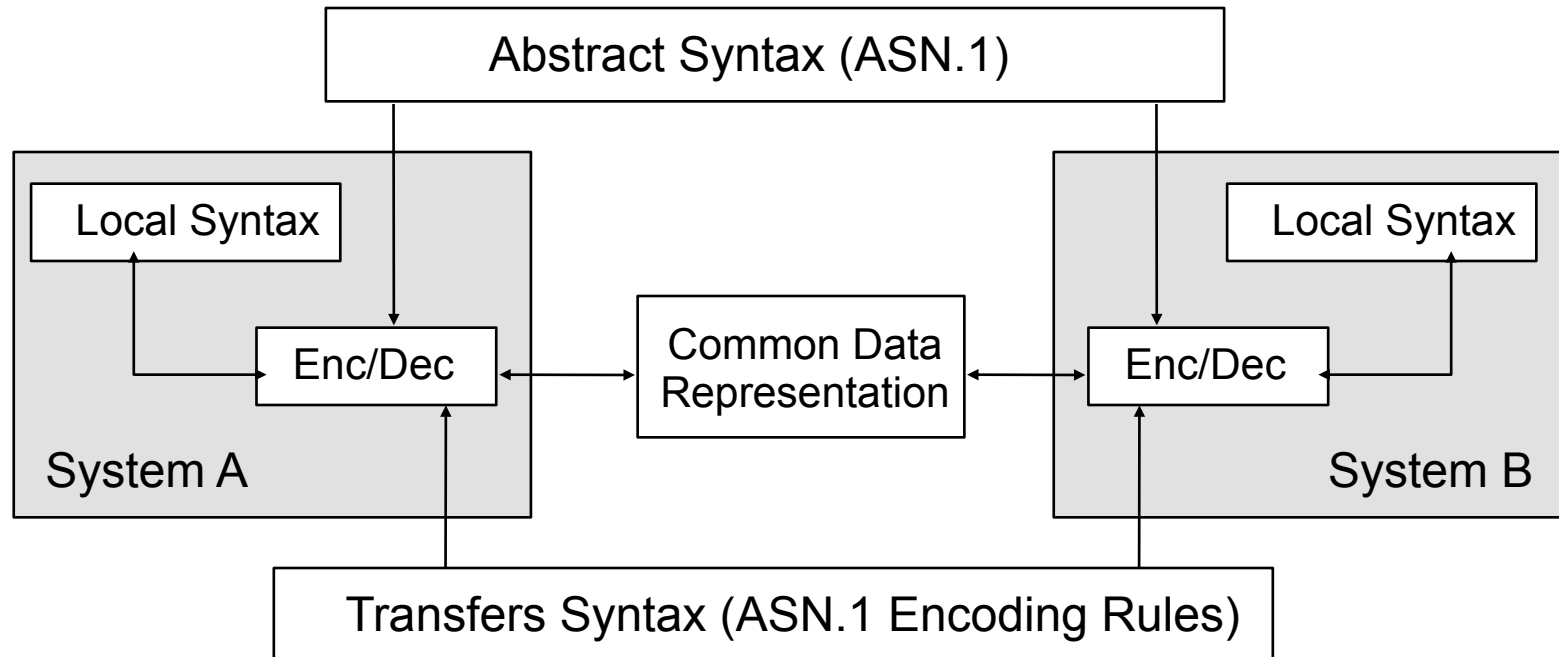

- ❑ ASN.1 defines a standardized abstract syntax.
- ❑ ASN.1 permits several encoding rules that transform the abstract syntax into a byte stream suitable for transfer. *BER* (Basic Encoding Rules) defines the mapping between abstract and transfer syntax.
- ❑ Applications normally use a local syntax depending on the programming language being used.

Primitive ASN.1 Datatypes

- Names of ASN.1 datatypes begin with a uppercase letter.
 - Names of ASN.1 values (constants) begin with a lowercase letter.
 - ASN.1 keywords and macro names consists only of uppercase letters.
 - Comments are enclosed between `--` (e.g. `-- This is a comment --`).
-
- ❑ BOOLEAN:
 - ↳ Can only take the predefined values TRUE and FALSE.
 - ❑ INTEGER:
 - ↳ Covers all the possible integer numbers. No delimitation of the number range.
 - ❑ BIT STRING:
 - ↳ A sequence of bits. The length does not have to be divisible by 8.
 - ❑ OCTET STRING:
 - ↳ A sequence of octets (bytes). It is the base type for different character sets and other derived types (`GeneralizedTime`, `UTCTime`).

Primitive ASN.1-Datatypes

- ❑ ENUMERATED:
 - ↳ Type of enumerating. Possible values must be determined by the definition of derived datatypes.
- ❑ OBJECT IDENTIFIER:
 - ↳ Unique identification of a node in the ISO registration tree.
 - ↳ Path of the root of the tree to the target node.
- ❑ ObjectDescriptor:
 - ↳ A character string for the identification of a node in the Registration tree.
 - ↳ Not necessarily unique.
- ❑ ANY:
 - ↳ any ASN.1-datatype (Union of all ASN.1 datatypes as C 'void').
- ❑ EXTERNAL:
 - ↳ Data not described using an ASN.1 definition.
- ❑ NULL:
 - ↳ A substitute symbol, in order to indicate in an assembled datatype the absence of a value.

ISO Registration Tree

- ❑ Used for uniquely identifying definitions, documents, objects...
- ❑ Hierarchical structure, similar to hierarchical file systems.
- ❑ All nodes of a level identified by a unique number.
- ❑ The path from the root of the registration tree to a node results in a numerical sequence called Object Identifier (e.g. 1.3.6.1).

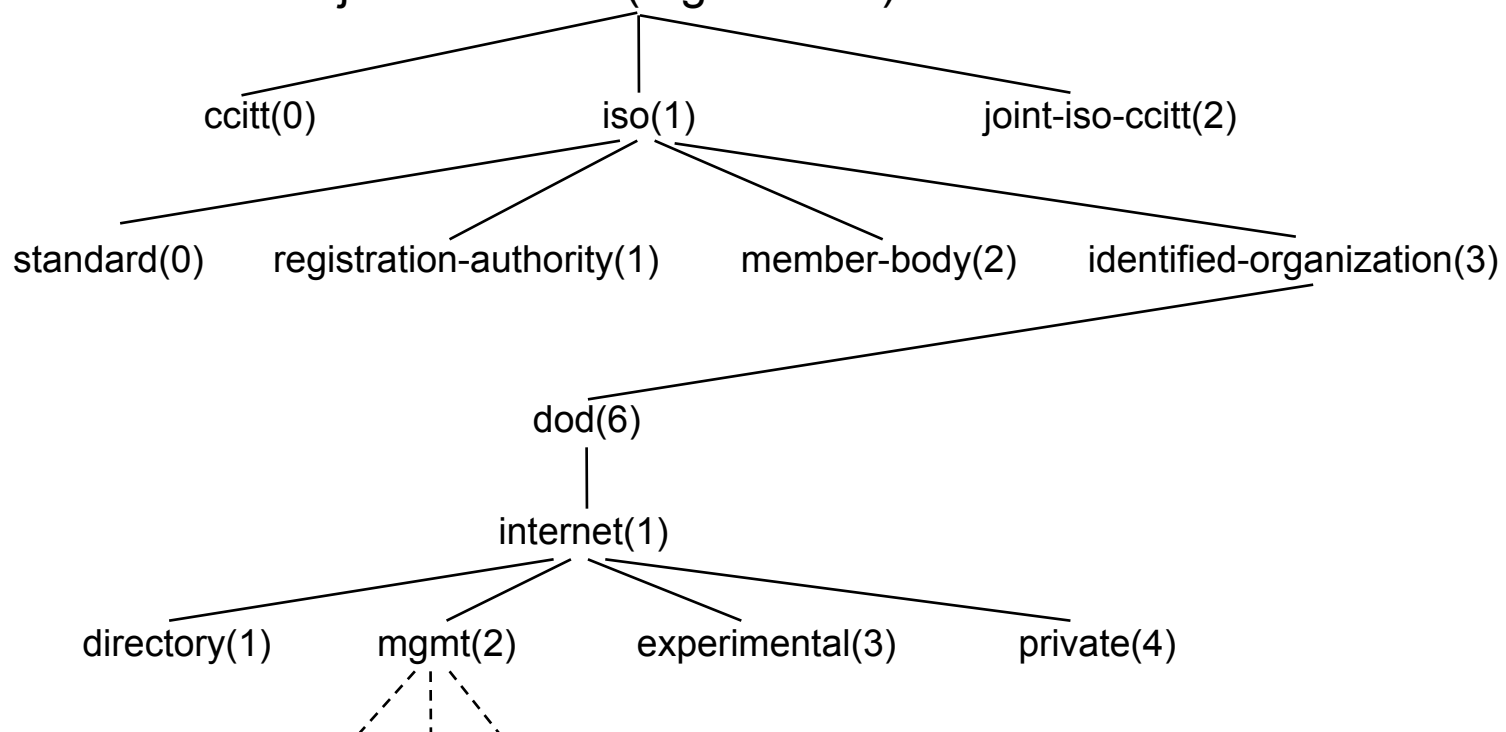

Assembled ASN.1 Datatypes

- ❑ SEQUENCE:
 - ↳ Corresponds to structures in C or records in Pascal.
 - ↳ The sequence of the items in a SEQUENCE is fixed.
- ❑ SET:
 - ↳ Similar to a SEQUENCE, with the difference that the sequence of the elements is not specified.
- ❑ SEQUENCE OF:
 - ↳ Ordered quantity (list) of homogeneous data.
- ❑ SET OF:
 - ↳ Unordered quantity of homogeneous data.
- ❑ CHOICE:
 - ↳ Type of selection, similar to the C union.
- ❑ REAL:
 - ↳ It consists of the INTEGER datatype extended with mantissa and exponent.

Reduced Datatypes

- ❑ Definition of further datatypes by restricting the scope of existing datatypes.
- ❑ Exact syntax dependent on the underlying primitive datatype.

- ❑ Examples:

```
LottoNumber ::= INTEGER (1..90)
```

```
MD5Key      ::= OCTET STRING (SIZE (16))
```

```
IPAddress   ::= OCTET STRING (SIZE (4|16))
```

```
Counter32   ::= INTEGER (0..4294967295)
```

```
Integer32   ::= INTEGER (-2147483648..2147483647)
```

```
Unsigned64  ::= INTEGER (0..18446744073709551615)
```

- ❑ Restrictions of the scope are applied to derived datatypes (e.g SEQUENCE OF MD5Key).
- ❑ The restriction of the INTEGER datatype makes sense as today's computers internally usually operate with 32-bit or 64-bit numbers.

Some Definitions of Types and Values

□ Type definitions:

Number ::= INTEGER

DateAndTime ::= UTCTime

ID ::= OBJECT Identifier

□ Value definitions :

ok BOOLEAN ::= TRUE

seven Number ::= 7

now DateAndTime ::= "971105012200-0100"

□ Implicit Value Definitions :

Lotto ::= INTEGER { first(1), last(49) }

AccessRight ::= BIT STRING { read(1), write(2), execute(3) }

MaskAccessRight ::= { read, execute }

Sex ::= ENUMERATED { female(1), male(0) }

A Complex Example [1/2]

```
Message ::= SEQUENCE {
    version INTEGER,
    community OCTET STRING,
    data ANY          -- e.g. PDUs if no authentication
}

PDUs ::= CHOICE {
    get-request      GetRequest-PDU,
    get-next-request GetNextRequest-PDU,
    get-response     GetResponse-PDU,
    set-request      SetRequest-PDU
}

GetRequest-PDU      ::= [ 0 ] IMPLICIT PDU
GetNextRequest-PDU ::= [ 1 ] IMPLICIT PDU
GetResponse-PDU     ::= [ 2 ] IMPLICIT PDU
SetRequest-PDU      ::= [ 3 ] IMPLICIT PDU
```

A Complex Example [2/2]

```
PDU ::= SEQUENCE {
    request-id      INTEGER,
    error-status    INTEGER {
        noError(0), tooBig(1),
        noSuchName(2), badValue(3),
        readOnly(4), genErr(5)
    },
    error-index     INTEGER,
    variable-bindings VarBindList
}
VarBindList ::= SEQUENCE OF VarBind
VarBind ::= SEQUENCE {
    name      ObjectName,
    value     ObjectSyntax
}
}
```

Basic Encoding Rules (BER)

- ❑ The Basic Encoding Rules determine how a ASN.1 datatype can be represented as a string of bytes.
- ❑ Based on tag/length/value coding (TLV) algorithm, where the each variable is identified by one tag, the length of the value in bytes and the value of those bytes.
- ❑ The TLV coding permits a recipient to reconstruct the type of a message from the received byte stream.
- ❑ BER coding is a little inefficient as there is often unnecessary information to be transferred.
- ❑ The use of OPTIONAL fields further complicated the BER definition.
- ❑ BER also defines the transmission direction of the bit stream other than the coding the ASN.1 datatypes:



Coding Tags Classes

- Each tags is coded in a byte:

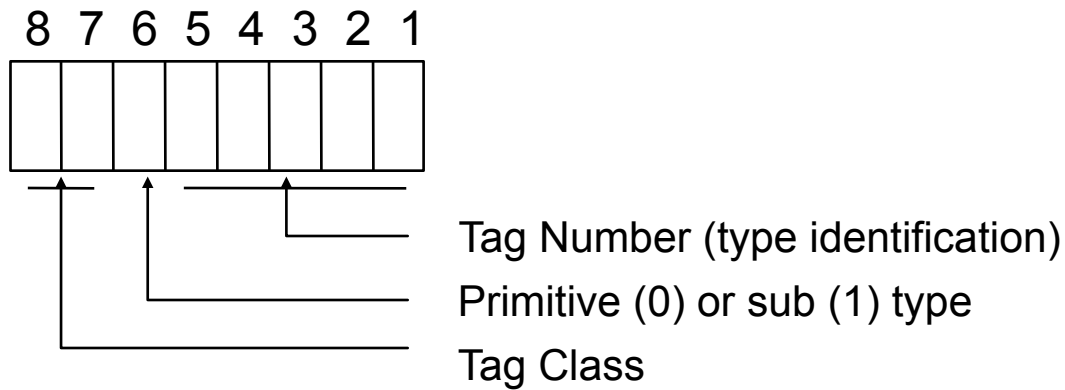

- Tag classes:

| | Bit 8 | Bit 7 |
|------------------|-------|-------|
| UNIVERSAL | 0 | 0 |
| APPLICATION | 0 | 1 |
| CONTEXT-SPECIFIC | 1 | 0 |
| PRIVATE | 1 | 1 |

Coding Field Length

- The length field indicates the length of the directly following value.

↳ Length within 0..127:

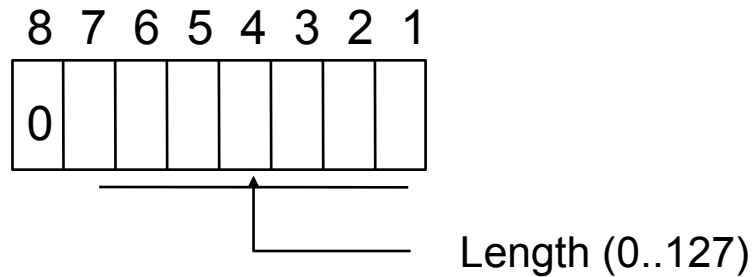

↳ Length > 127 :

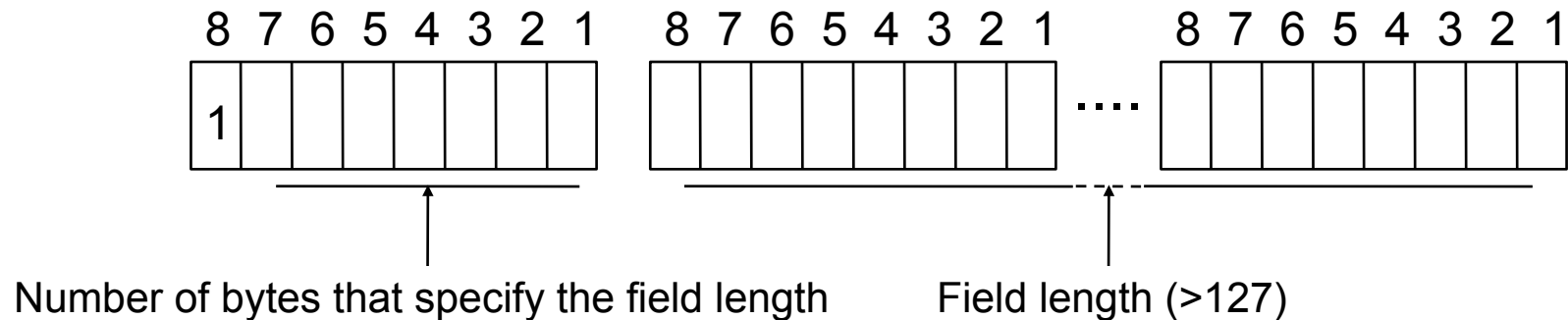

Value Coding

- ❑ For each primitive ASN.1 type there is a rule that allows values to be translated into a stream of bytes and vice-versa.
- ❑ The rules for `INTEGER` and `OCTET STRING` are simple.
- ❑ The rules for `OBJECT IDENTIFIER` are relatively complex.
- ❑ Assembled values (`SEQUENCE`, `SEQUENCE OF`) are easily represented by coding each individual item.
- ❑ With `CHOICE` constructs only the available value is transferred, therefore the associated tag must be unique.
- ❑ For further details:

D. Steedman: *Abstract Syntax Notation One (ASN.1) - The Tutorial and Reference*,
Technology Appraisals, 1990

Example of a BER Coded Message

| | | |
|----|----------------------|----------------------------------|
| 30 | 1B | SEQUENCE, Length 27 |
| 02 | 01 00 | INTEGER, Length 1, "0" |
| 04 | 06 70 75 62 6C 69 63 | OCTET STRING, Length 6, "public" |
| A1 | 0E | GetNextRequest-PDU, Length 14 |
| 02 | 04 36 A2 8F 07 | INTEGER, Length 4, "916623111" |
| 02 | 01 00 | INTEGER, Length 1, "0" |
| 02 | 01 00 | INTEGER, Length 1, "0" |
| 30 | 00 | SEQUENCE OF, Length 0 |

- ❑ Length of the BER encoding must be well known (no dummy values) when a value is coded. With some restrictions it is also possible to specify the length after the value.
- ❑ The decoding is more difficult when the length is specified after the value.
- ❑ Coding the primitive values is not always as simple as in the example (some datatypes can be encoded in both short and long form).

An ASN.1 Compiler [1/2]

ASN.1

```
CertainStructure ::= SEQUENCE {  
    tag    VisibleString,  
    val1   INTEGER,  
    val2   INTEGER OPTIONAL,  
    reals  SET OF REAL  
}
```

C

```
typedef struct CertainStructure {  
    VisibleString_t tag;  
    int            val1;  
    int            *val2;    /* OPTIONAL */  
    A_SET_OF(double) reals;  
} CertainStructure_t;
```

An ASN.1 Compiler [2/2]

Encoding and Decoding Data

```
CertainStructure_t *cs = 0;
```

```
ber_decode(0, &asn_DEF_CertainStructure, &cs, buffer, buffer_length);
```

```
cs->val1 = 123;    /* Modify the contents */
```

```
ber_encode(&asn_DEF_CertainStructure, cs, write_handle, 0);
```

Online ASN.1 Compiler

<http://lionet.info/asn1c/asn1c.cgi>

2. Internet Management

1. Introduction

2. **Internet Management**

2.1 Overview

2.2 Structure the Management Information (SMIv2)

2.3 Fundamental MIBs

2.4 Simple Network Management Protocol Version 1 (SNMPv1)

2.5 Simple Network Management Protocol Version 2c (SNMPv2c)

2.6 Simple Network Management Protocol Version 3 (SNMPv3)

2.7 MIB Implementation and Agent Extensibility Protocol (AgentX)

2.1 Overview

| | | |
|------|---|--------------------|
| 1987 | Simple Gateway Monitoring Protocol (SGMP) | |
| 1987 | High-level Entity Management System (HEMS) | |
| 1988 | Simple Network Management Protocol (SNMPv1) | proposed |
| 1990 | Simple Network Management Protocol (SNMPv1) | standard 15, 16 |
| 1991 | Management Information Base II | standard 17 |
| 1993 | SNMP Version 2 (Party/Party/Context) | historical |
| 1996 | SNMP Version 2 (Communities) | draft/experimental |
| 1998 | SNMP Version 3 (User-based) | draft |

- SNMPv1 has a large spreading particularly in data communication.
- The attempts for the standardisation of SNMPv2 failed.
- SNMPv3 with SNMPv1 has been accepted by a large community of network manufacturers.
- The user community has accepted SNMPv3 very well in terms of support and development.

SNMP Development Goals

- ❑ Minimization of the number and complexity of the management functions, which are implemented by an agent:
 - ↳ Reduction of development costs for management agents (simple applications).
 - ↳ Ubiquity: use the same management technology for all devices (printers or Cray).
 - ↳ Application extensibility: development of new management functions without the need to modify the agents.

- ❑ Extensibility by defining new MIBs.
- ❑ Independence from existing computer or network architectures.
- ❑ Robustness by a simple, connectionless transport service (UDP).
- ❑ No dependency on other network services.
- ❑ Addition of management to new/existing devices/applications should be inexpensive, simple to develop and of limited functionality.
- ❑ Unfortunately some of these original goals have been lost: the term "simple" refers to the protocol and not to the specifications or the implementation of management applications.

Trap Directed Polling

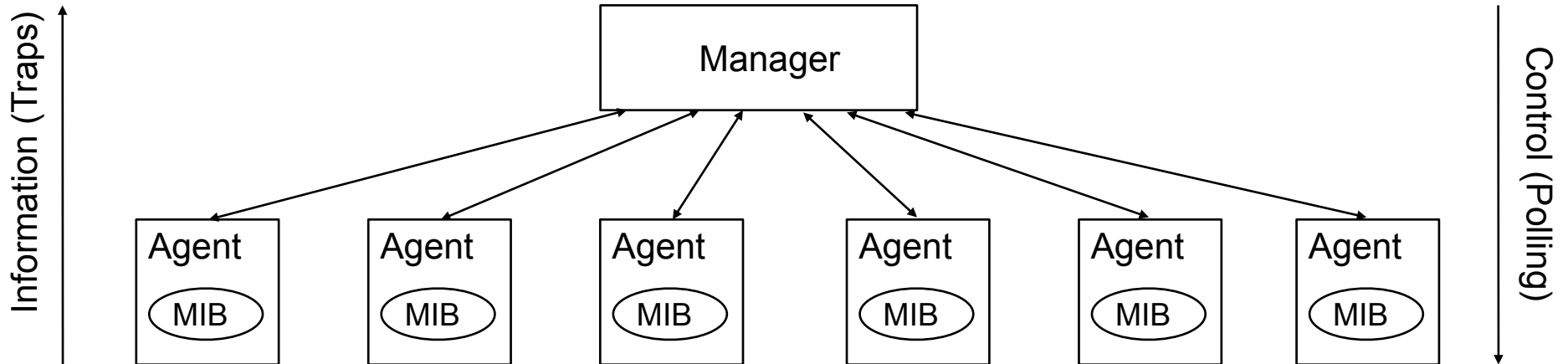

- ❑ SNMP managers polls in regular intervals the SNMP agents.
- ❑ Agents can signal exceptional cases to a manager by sending a trap.
- ❑ The SNMP manager can adapt the polling strategy upon the receipt of traps (trap directed polling).
- SNMP is a strictly centralized model, where the manager implements the whole functionality and responsibility.

SNMP Application Areas

- ❑ SNMP can be used not only for network management:
 - ↳ control and monitoring of production processes.
 - ↳ control and monitoring of complex computer systems.
 - ↳ monitoring of complex application programs (relational databases, SAP R/3 components...).

- Many good SNMP toolkits are available on the market.

- Very few applications are available for solving complex management problems.

- The implementation of special applications or the conversion of local procedure guidelines is generally relatively complex and expensive.

2.2 Structure the Management Information (SMIv2)

- ❑ The current information model known as "*Structure of Management Information version 2*" (SMIv2) is defined and based on simple typed variables.
- ❑ SMIv2 is based on extended subset of ASN.1 (1998).
- ❑ Each variable has a primitive, not assembled ASN.1 datatype:
 - ↳ INTEGER, OCTET STRING, OBJECT IDENTIFIER, NULL
 - ↳ Integer32, Unsigned32, Gauge32, Counter32, Counter64, IpAddress, TimeTicks, Opaque
- ❑ It does not implement complex data structures and operations on the variables.
- ❑ Variables are either scalars (exactly one instance) or columns in a "conceptual" two dimensional table (zero or several variables).
- ❑ On the variables only "read" and "write" operations can be applied. However the SNMP protocol permits the manipulation of lists of variables.
- ❑ SMIv2 management information Bases (MIBs) are defined using special ASN.1 macros.
- ❑ It leverages the complexity of new MIBs definitions: definition of basic functionality and primitive types to be used in new MIBs.

SMIv2 Basic Datatypes (RFC 2578)

| SMIv2 | SMIv1 | Description |
|-------------------|-------------------|--|
| INTEGER | INTEGER | Integer Numbers (-2147483648..2147483647) |
| OCTET STRING | OCTET STRING | Sequence of bytes (octets). |
| OBJECT IDENTIFIER | OBJECT IDENTIFIER | Unique identifier. |
| Integer32 | INTEGER | 32 bit Integers (-2147483648..2147483647) |
| Unsigned32 | - | 32 bit Positive Integers (0..4294967295) |
| Gauge32 | Gauge | “Thermometer“ Integer (0..4294967295) |
| Counter32 | Counter | 32 bit non decreasing counter (0..4294967295) |
| Counter64 | - | 64 bit non decreasing counter (0..18446744073709551615) |
| TimeTicks | TimeTicks | Time in 1/100th of seconds |
| IpAddress | IpAddress | 4 Byte IPv4 Address |
| Opaque | Opaque | Unspecified ASN.1 Type (not recommended) |
| BITS | - | Bits in a OCTET STRING |
| - | NetworkAddress | Network Address (not recommended) |

A MIB Use Case

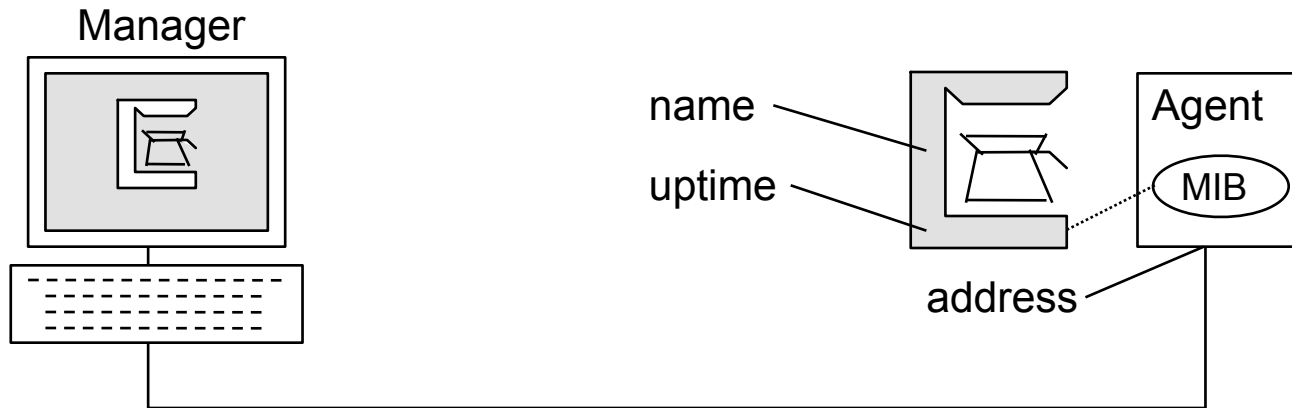

- ❑ Definition of the variables in the ISO Registration tree.
- ❑ Nodes are defined for naming purposes.
- ❑ The leaf of the tree represent the managed objects (i.e. “the meat”).
- ❑ Sub nodes can be used in order to logically organise the object types.

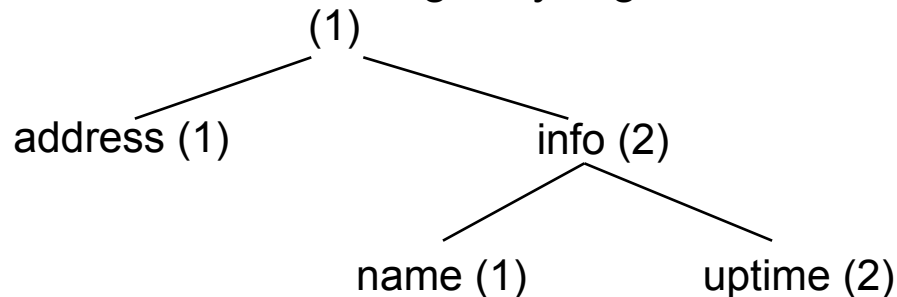

Object Identifier and Instance Identifier

- ❑ In the registration tree each object can be identified by means of a unique object identifier.
- ❑ Concrete developments (instance) of a type of object are unique designated by a so-called *Instance Identifier*.
- ❑ A unique instance identifier is obtained by attaching an instance identifiers to the object identifier.
- ❑ Scalar object have basically only one instance, where the instance identifier has basically the value 0 (e.g. sysName.0).
- ❑ Instance identifiers for non-scalar variables are derived from the unique naming of a conceptual table.
- ❑ As object identifier can have up to 128 elements, hence instance names cannot be infinitely complex.

Example of Object and Instance Identifiers

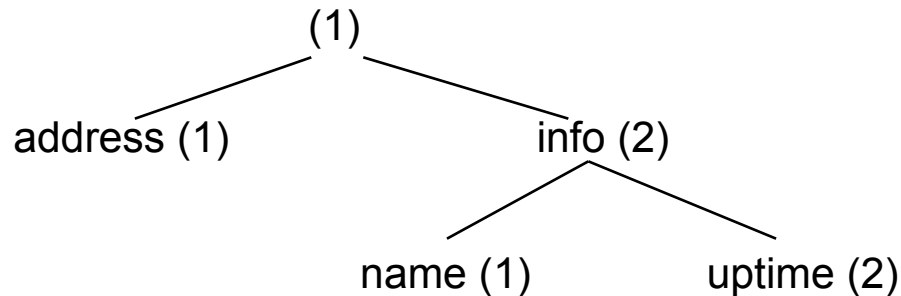

| Object Identifier | Instance Identifier | Type | Value |
|-------------------|---------------------|--------------|---------------|
| 1.1 | 0 | IpAddress | 10.1.2.1 |
| 1.2.1 | 0 | OCTET STRING | "FilterFresh" |
| 1.2.2 | 0 | TimeTicks | 54321 |

- MIB nodes names are relevant for human users only.
- Descriptors must be unique within a MIB module, although can be used several times in different MIB modules (one gets unique descriptors by the combining module names and descriptors).

Extension of the Example MIB with a Routing table

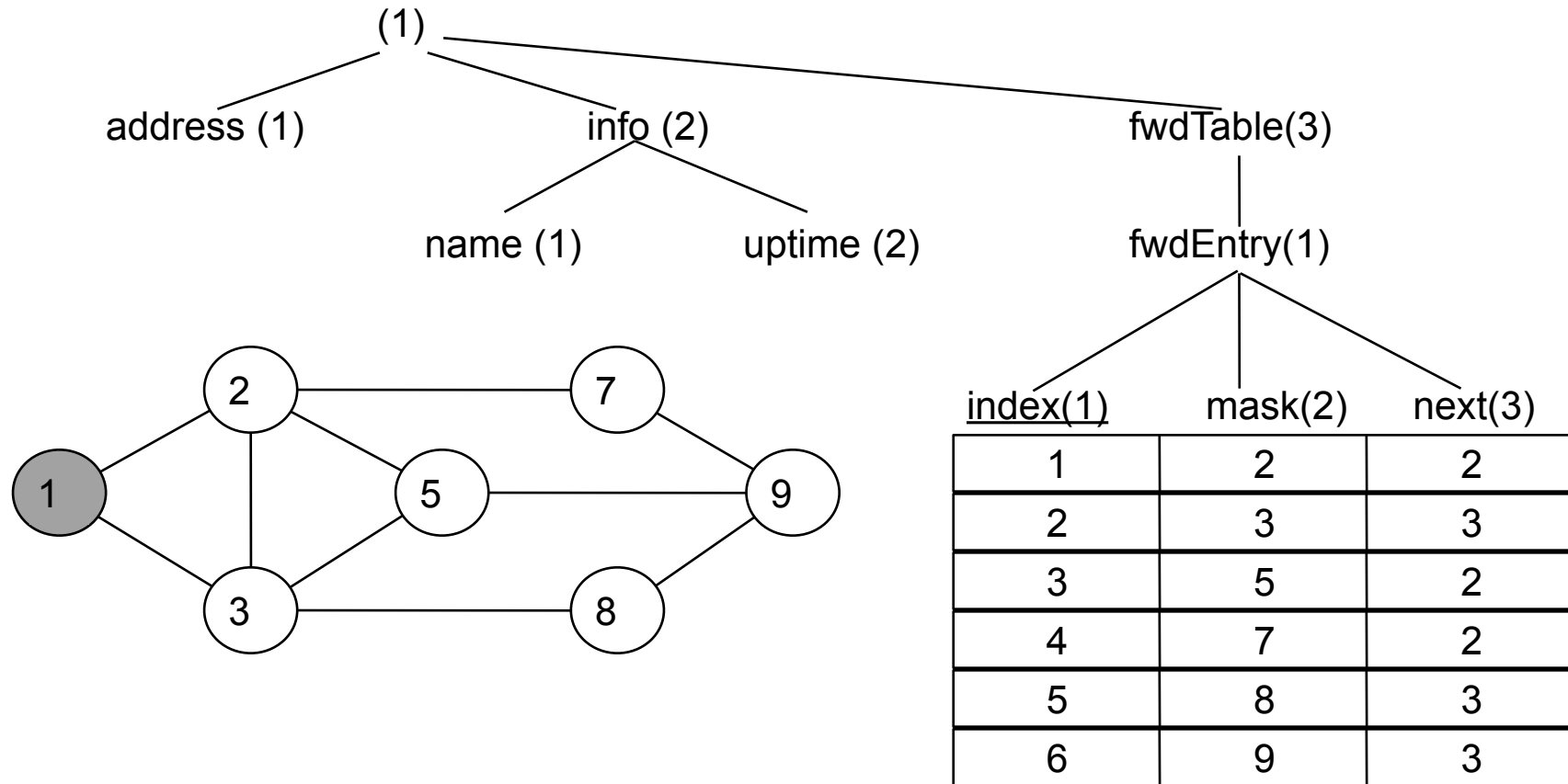

- For matter of simplicity in the above example addresses are represented using natural numbers.

Identification of Table Entries

- ❑ Tables are defined basically with two "auxiliary nodes":
 - ↳ the first node defines the table and is of type `SEQUENCE OF`.
 - ↳ the second node defines an entry (a row) in the table and is of type `SEQUENCE`.
 - ↳ this is the only permitted use of `SEQUENCE` and `SEQUENCE OF` in SNMP SMIv2.

- ❑ The result of the column and instance identifier (code of the table) is a unique object identifier for each table entry.

- ❑ Table Example (convention OID => value):

| | | |
|----------------|----------------|---------------------------|
| 1.3.1.1.1 => 1 | 1.3.1.3.1 => 2 | 1.3.1.2.4 => 7 |
| 1.3.1.2.1 => 2 | 1.3.1.1.4 => 4 | 1.3.1.2.7 => not existing |

Tables Naming [1/3]

- ❑ Table naming is very important as it affects the way tables are accessed.
- ❑ Two kind of tables naming:
 - ↳ Use row numbers (not being used by SNMP).

| | | |
|---|---|---|
| 1 | 2 | 2 |
| 2 | 3 | 3 |
| 3 | 5 | 2 |
| 4 | 7 | 2 |
| 5 | 8 | 3 |

← This is row number 3

- ↳ Use an index column (the SNMP way).

↓ This is the index column

| | | |
|---|---|---|
| 1 | 2 | 2 |
| 2 | 3 | 3 |
| 3 | 5 | 2 |
| 4 | 7 | 2 |
| 5 | 8 | 3 |

Tables Naming [2/3]

- ❑ A table index is not necessarily an INTEGER. For instance the routingTable uses an IP address as table index.
- ❑ A table index can be made of several components:

↪ X . C . I1 . I2 In
 OID of the table
 Column number
 Index value 1
 Index value n

routingTable

policy (2) 1 = low cost
 2 = high reliability

| destination (1) | | next (3) |
|-----------------|---|---------------|
| 130.89.16.23 | 1 | 130.89.16.23 |
| 130.89.16.23 | 2 | 130.89.16.127 |
| 192.168.10.12 | 1 | 172.16.1.18 |
| 192.168.10.12 | 2 | 172.16.1.12 |

Rules for the Specification of Instance Identifier values

- ❑ Values for fundamental types:
 - ↳ Values for `INTEGER`:
A single integer value.
 - ↳ Values for fixed length `OCTET STRING`:
Each individual byte is treated as an individual value.
 - ↳ Values for variable length `OCTET STRING`:
The first value is the length, followed by each individual byte.
 - ↳ Values for `OBJECT IDENTIFIER`:
The first value is the length, followed by each individual byte.
- ❑ The `IMPLIED` keyword can be used without the length byte if it does not lead to ambiguities.
- ❑ The max length of `OBJECT IDENTIFIER` values is limited to 128 items, so instance identifiers will not be arbitrary complex.

MIB Module

- ❑ Similar object types are combined into MIB modules.
- ❑ Each MIB module must have a unique name (uppercase letters).
- ❑ MIB modules are (almost) normal ASN.1 modules and obey to the lexical ASN.1 rules.
- ❑ Definitions can be imported by other MIB modules with the help of of the ASN.1 `IMPORT` statement.
- ❑ All used ASN.1 SMI Macros must be explicitly imported

```
COFFEE-MIB DEFINITIONS ::= BEGIN
```

```
IMPORT      MODULE-IDENTITY, OBJECT-TYPE, enterprises,  
            IpAddress, TimeTicks FROM SNMPv2-SMI;
```

```
...
```

```
END
```

Module-Identities (RFC 2578)

```
<descriptor> MODULE-IDENTITY
    LAST-UPDATED <ExtUTCTime>
    ORGANIZATION <Text>
    CONTACT-INFO <Text>
    DESCRIPTION <Text>
    [REVISION <ExtUTCTime>
    DESCRIPTION <Text>]*
 ::= <ObjectIdentifier>
```

- ❑ Defines administrative information e.g. contact information and version number.
- ❑ the REVISION and DESCRIPTION clauses are not mandatory and can occur several times.
- ❑ ExtUTCTime contains a date in the format „YYMMDDHHMMZ“ (UTC) or „YYYYMMDDHHMMZ“, e.g.. „9502192015Z“ or „199502192015Z“.

Example of Module Identities (RFC 2233)

```
IF-MIB DEFINITIONS ::= BEGIN
IMPORTS ...
ifMIB MODULE-IDENTITY
    LAST-UPDATED "9611031355Z"
    ORGANIZATION "IETF Interface MIB Working Group"
    CONTACT-INFO " Keith McCloghrie          408-526-5260
                  Cisco Systems, Inc.      kzm@cisco.com
                  170 West Tasman Drive
                  San Jose, CA 95134-1706, US"
    DESCRIPTION "The MIB module to of describe generic objects for network interface
                sub-layers. This MIB is an updated version of MIB II's ifTable,
                and incorporates the extensions defined in RFC 1229."
    REVISION     "9602282155Z"
    DESCRIPTION "Revisions made by the Interfaces MIB WG"
    REVISION     "9311082155Z"
    DESCRIPTION "Initial revision, published as part of RFC 1573."
    ::= { mib-2 31 }

...
```

Object Identities (RFC 2578)

```
<descriptor> OBJECT-IDENTITY
    STATUS          <Status>
    DESCRIPTION     <Text>
    [REFERENCE      <Text>]
    ::= <ObjectIdentifier>
```

- ❑ Defines and registers an object identifier value.
- ❑ Permits the allocation of any node within the registration tree.
- ❑ The `STATUS` clause defines whether the allocated node is "obsolete" "current", or "deprecated".
- ❑ The optional `REFERENCE` is used to refer to further information (similar to HTML hyperlinks).

Example of Object Identities (RFC 2578, RFC 1906)

zeroDotZero OBJECT-IDENTITY

STATUS current

DESCRIPTION

"A value used for null Identifiers."

::= { 0 0 }

snmpUDPDomain OBJECT-IDENTITY

STATUS current

DESCRIPTION

"The SNMPv2 over UDP transport domain. The corresponding transport address is of type SnmpUDPAddress."

::= { snmpDomains 1 }

snmpIPXDomain OBJECT-IDENTITY

STATUS current

DESCRIPTION

"The SNMPv2 over IPX transport domain. The corresponding transport address is of type SnmpIPXAddress."

::= { snmpDomains 5 }

Object Types (RFC 2578)

```
<descriptor> OBJECT-TYPE
    SYNTAX          <Syntax>
    [ UNITS          <Text> ]
    MAX-ACCESS      <Access>
    STATUS          <Status>
    DESCRIPTION     <Text>
    [ REFERENCE     <Text> ]
    [ INDEX         <Index> ]
    [ AUGMENTS      <Index> ]
    [ DEFVAL        <Value> ]
    ::= <ObjectIdentifier>
```

- ❑ Macro for the definition of object types and conceptual tables.
- ❑ The INDEX and AUGMENTS clauses are permitted only for the definition by tables.
- ❑ Exactly one of the above clauses must be specified during table definition.

Example for ObjectTypes (RFC 2012)

tcpRtoMin OBJECT-TYPE

SYNTAX Integer32

UNITS "milliseconds"

MAX-ACCESS read-only

STATUS current

DESCRIPTION

"The minimum value permitted by a TCP implementation for the retransmission timeout, measured in milliseconds. More refined semantics for objects of this type depend upon the algorithm used to determine the retransmission timeout. In particular, when the timeout algorithm is rsre(3), an object of this type has the semantics of the LBOand quantity of thecribed in RFC 793."

::= { tcp 2 }

Example for ObjectTypes (RFC 1907)

sysORTable OBJECT-TYPE

SYNTAX SEQUENCE OF SysOREntry

MAX-ACCESS not-accessible

STATUS current

DESCRIPTION

"The (conceptual) table listing the capabilities of the local SNMPv2 entity acting in an agent role with respect to various MIB modules. SNMPv2 entities having dynamically-configurable support of MIB modules will have a dynamically-varying number of conceptual rows."

::= { system 9 }

sysOREntry OBJECT-TYPE

SYNTAX SysOREntry

MAX-ACCESS not-accessible

STATUS current

DESCRIPTION

"An entry (conceptual row) in the sysORTable."

INDEX { sysORIndex }

::= { sysORTable 1 }

Notification-Types (RFC 2578)

```
<descriptor> NOTIFICATION-TYPE
    [ OBJECTS      <Objects> ]
    STATUS        <Status>
    DESCRIPTION   <Text>
    [ REFERENCE   <Text> ]
    ::= <ObjectIdentifier>
```

- ❑ Macro for the registration of an event.
- ❑ In case of event a manager or an agent can send an appropriate notification to another manager.
- ❑ The OBJECTS clauses defines which MIB objects must be contained in the event description.
- ❑ The DESCRIPTION clause must describe which instances are meant in each case.

Example for Notification Types (RFC 2233)

linkDown NOTIFICATION-TYPE

OBJECTS { ifIndex, ifAdminStatus, ifOperStatus }

STATUS current

DESCRIPTION

"A linkDown trap signifies that the SNMPv2 entity, acting in an agent role, has detected that the ifOperStatus object for one of its communication links is about to enter the down state from some other state (but not from the notPresent state). This other state is indicated by the included value of ifOperStatus."

::= { snmpTraps 3 }

linkUp NOTIFICATION-TYPE

OBJECTS { ifIndex, ifAdminStatus, ifOperStatus }

STATUS current

DESCRIPTION

"A linkDown trap signifies that the SNMPv2 entity, acting in an agent role, has detected that the ifOperStatus object for one of its communication links left the down state and transitioned into some other state (but not into the notPresent state). This other state is indicated by the included value of ifOperStatus."

::= { snmpTraps 4 }

New Types from Textual Conventions

- ❑ Textual conventions allow new types to be derived from SMIv2 base types.
- ❑ However, additional types may not be derived from a textual convention.
- ❑ A `DISPLAY-HINT` clause defines a simple figure of the ASN.1 representation of a value into a format readable for humans.
- ❑ The `DISPLAY-HINT` clause can be used only together with the `INTEGER` and `OCTET STRING` datatype and from which it derives.
- ❑ A Textual convention can determine restrictions on the scope.
- ❑ A Textual convention cannot define an assembled type.

Textual Conventions [1/2]

- ❑ Textual conventions are defined in RFC 2579.

```
<descriptor> ::= TEXTUAL-CONVENTION
                [ DISPLAY-HINT <Text> ]
                STATUS      <Status>
                DESCRIPTION  <Text>
                [ REFERENCE  <Text> ]
                SYNTAX       <Syntax>
```

- ❑ The `DISPLAY-HINT` clause defines a bi-directional figure of the internally used representation on a representation readable for humans. .
- ❑ In the `SYNTAX` clause only base datatypes may be used (one can thus limit not existing Textual Conventions even further).
- ❑ All further semantics must be defined in the `DESCRIPTION` clause.

Textual Conventions [2/2]

- The followings are the textual conventions defined in RFC 2579:
 - ↳ PhysAddress
 - ↳ MacAddress
 - ↳ TruthValue
 - ↳ AutonomousType
 - ↳ InstancePointer
 - ↳ VariablePointer
 - ↳ RowPointer
 - ↳ RowStatus
 - ↳ TimeStamp
 - ↳ TimeInterval
 - ↳ DateAndTime
 - ↳ StorageType
 - ↳ TDomain
 - ↳ TAddress

INTEGER DISPLAY-HINTS

| Format | Description |
|------------|--|
| d | Representation of an Integer |
| d-<number> | Representation of `d` with a decimal point |
| o | Octal Representation |
| x | Hex Representation |

□ Example:

- ↳ `"d"` stands for `"143"`
- ↳ `"d-2"` stands for `"1.43"`
- ↳ `"o"` stands for `"217"`
- ↳ `"x"` stands for `"8F"`

OCTET STRING DISPLAY-HINTS

[<repeat>]<number><format> [separator] [terminator]

| Field | Description (similar to C/C++ printf) |
|--------------|---|
| <repeat> | Indicator for the specification repetition |
| <number> | # bytes in the following format field |
| <format> | Format (a ASCII, d Decimal, x Hexadecimal, o Octal, t UTF8) |
| <separator> | Separator among multiple values |
| <terminator> | Terminator specified at the end of the rule |

□ Example:

- ↳ `“255a”` format for the ASCII characters `“aBc”` in the string `“aBc”`
- ↳ `“1x:”` format for the ASCII characters `“aBc”` in the string `“61:42:63”`
- ↳ `“0aH0ae0a10a10ao0a 1a”`
format for the ASCII characters `“World”` in the string `“Hello World”`

Example for Textual-Conventions (RFC 2579)

RunState ::= TEXTUAL-CONVENTION

STATUS current

DESCRIPTION

"This TC of describes the current execution state of a running application or process."

SYNTAX INTEGER {

running(1), runnable(2),

waiting(3), exiting(4), other(5)

}

MacAddress ::= TEXTUAL-CONVENTION

DISPLAY-HINT "lx:"

STATUS current

DESCRIPTION

"Represents an 802 MAC address represented in the `canonical' or the defined by IEEE 802.1a, i.e., as if it were transmitted least significant bit first, even though 802.5 (in contrast to other 802.x protocols) requires MAC addresses to be transmitted most significant bit first."

SYNTAX OCTET STRING (SIZE (6))

Example for Textual-Conventions (RFC 2579)

DateAndTime ::= TEXTUAL-CONVENTION

DISPLAY-HINT "2d-1d-1d,1d:1d:1d.1d,1ald:1d"

STATUS current

DESCRIPTION

"A date-time specification.

| field | octets | contents | range |
|-------|--------|--------------------------|-----------|
| ----- | ----- | ----- | ----- |
| 1 | 1-2 | year | 0..65536 |
| 2 | 3 | month | 1..12 |
| 3 | 4 | day | 1..31 |
| 4 | 5 | hour | 0..23 |
| 5 | 6 | minutes | 0..59 |
| 6 | 7 | seconds | 0..60 |
| | | (use 60 for leap-second) | |
| 7 | 8 | deci-seconds | 0..9 |
| 8 | 9 | direction from UTC | '+' / '-' |
| 9 | 10 | hours from UTC | 0..11 |
| 10 | 11 | minutes from UTC | 0..59 |

For example, Tuesday May 26, 1992 at 1:30:15 PM EDT would be displayed as:

1992-5-26,13:30:15.0,-4:0

Note that if only local time is known, then timezone information (fields 8-10) is not present."

SYNTAX OCTET STRING (SIZE (8 | 11))

Further SMIv2 Macros

- ❑ OBJECT-GROUPS
 - ↳ It enables the definition of groups of related object types.
 - ↳ This macro can be used in the MODULE-COMPLIANCE macro.

- ❑ NOTIFICATION-GROUPS
 - ↳ It enables the definition of groups of related notification types.
 - ↳ This macro can be used in the MODULE-COMPLIANCE macro.

- ❑ MODULE-COMPLIANCE
 - ↳ It defines one or more constraints that a MIB implementations must fulfil.

- ❑ AGENT-CAPABILITIES
 - ↳ It describes the capabilities of a real MIB implementation.

MIB-Compiler

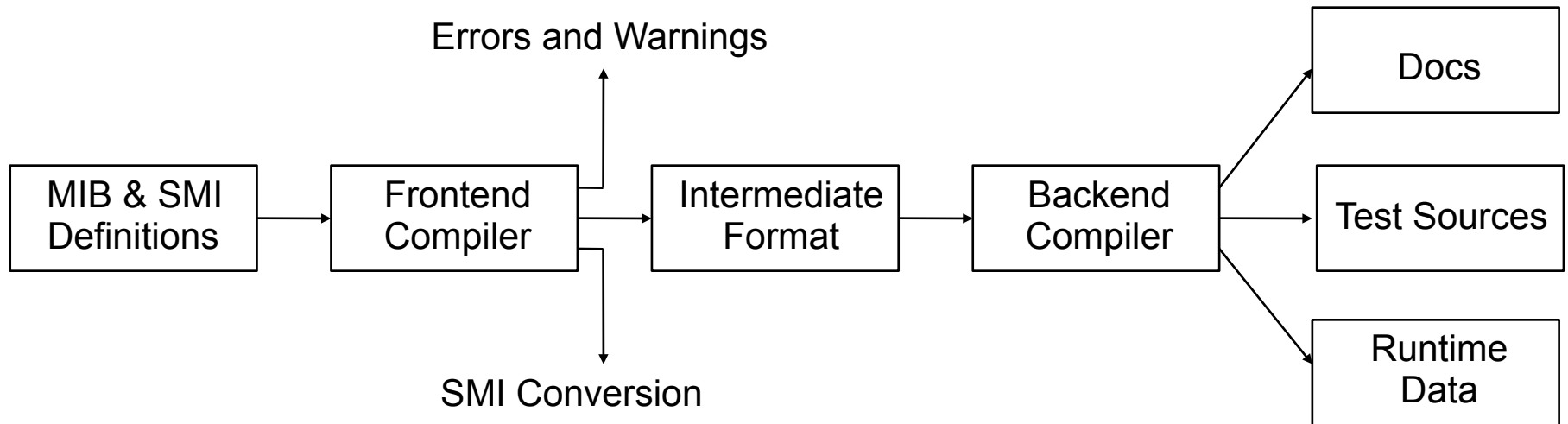

- ❑ Backend-Compiler can produce the following outputs:
 - ↳ Documentation (hypertext versions of MIB modules, diagrams)
 - ↳ Source code for the semiautomatic implementation of agents
 - ↳ Test-cases for testing manager and agent implementations
 - ↳ Inputs for management applications, the MIB definitions needed at run-time.
- There is no standardised or generally accepted intermediate format.

Agent Test Cases

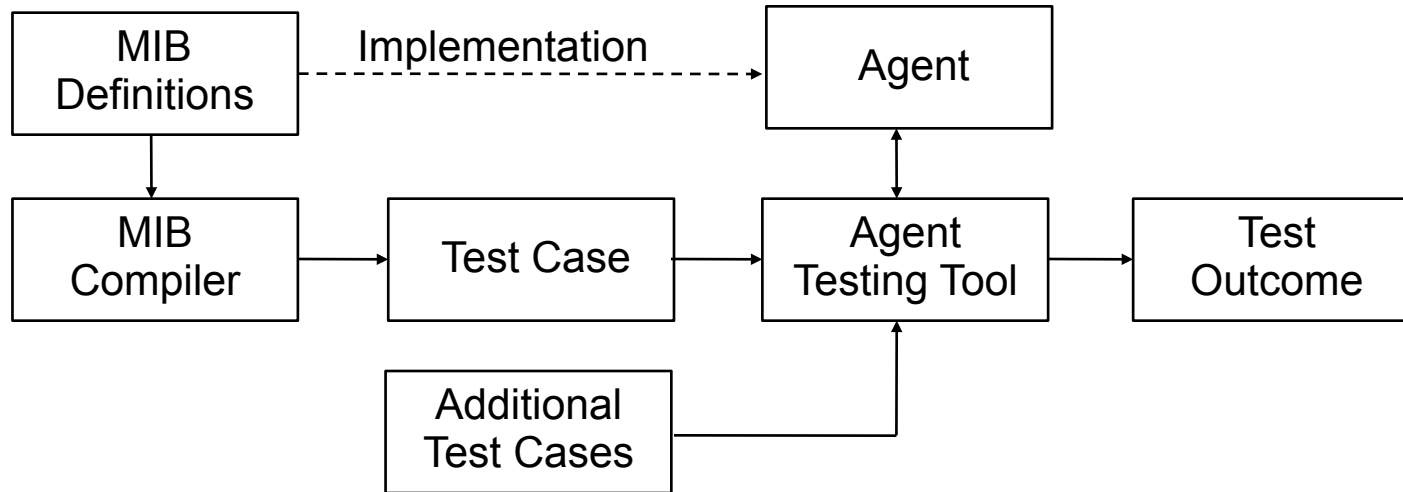

- ❑ Automatic regression tests for quality assurance.
- ❑ Many test cases can be generated automatically from MIB definitions:
 - ↳ Tests for the validation of the object types (type mismatch check).
 - ↳ Tests for checking correct protocol behaviour in particular with incorrect protocol messages.
 - ↳ Tests for checking correct lexicographical order of MIB instances.
- ❑ Additional in-depth test cases should be written by an independent (i.e. not the one who developed the agent) software developer on base of the MIB definition.

2.3 Fundamental MIBs

- ❑ MIB-II (RFC 1213) defines object types for the Internet Protocols IP, ICMP, UDP, TCP, SNMP (and other definitions not relevant here). Basically it models the management of the TCP/IP protocol stack.

- ❑ Goals of the MIB-II definition:
 - ↳ Define basic error and configuration management for Internet protocols.
 - ↳ Very few and weak control objects.
 - ↳ Avoidance of redundant information in the MIB.
 - ↳ MIB implementation should not interfere with the normal network activities.
 - ↳ No implementation-dependent object types.

- ❑ Altogether 170 object types.
 - Some MIB definitions turned out to be too simple and minimal (Routing table, Interface table).
 - Some MIB definitions presuppose a 4-Byte address format, hence these tables must be redefined for IP version 6 (IPv6).

Registration and Structure of MIB-II

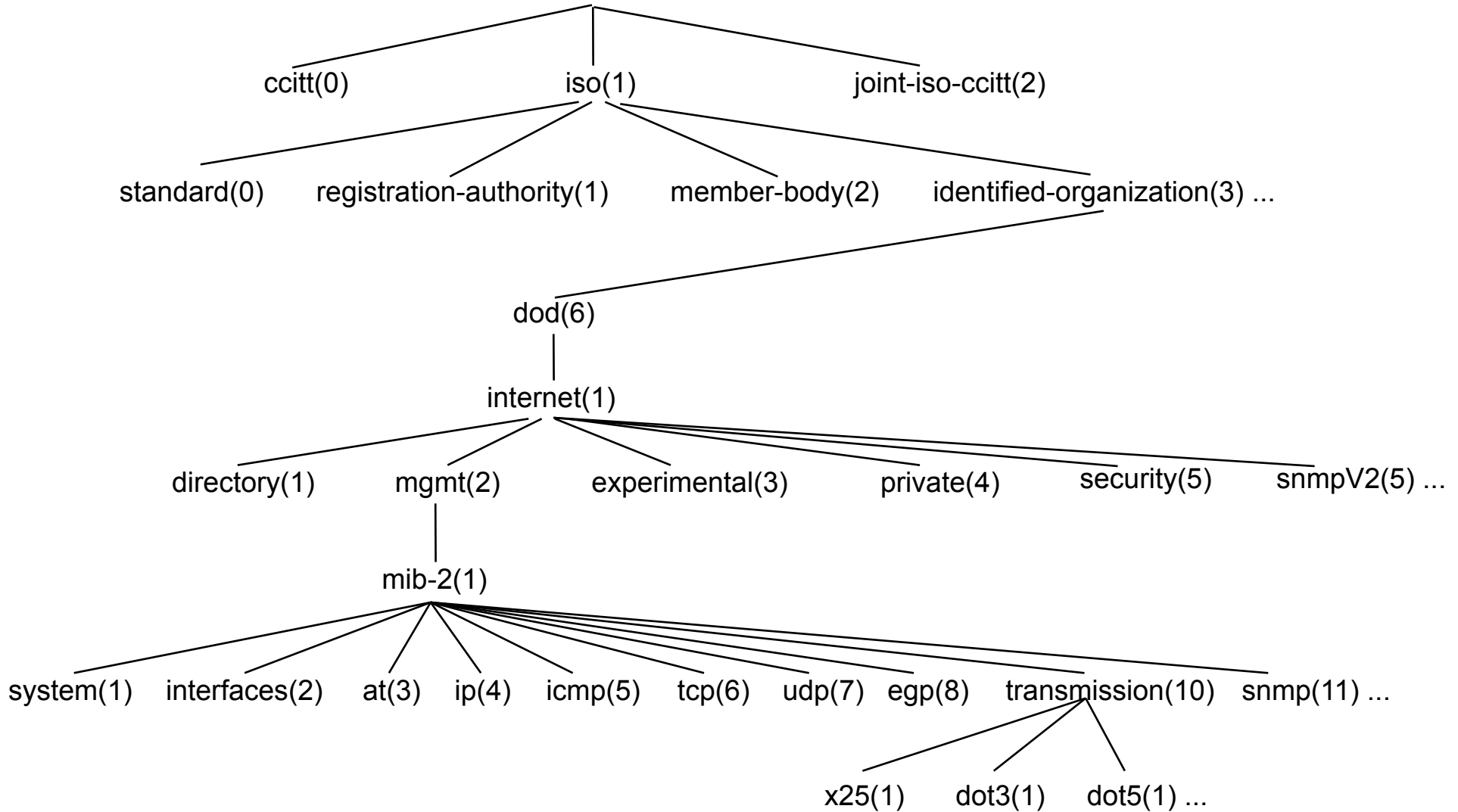

Remarks on MIB-II

- ❑ The “transmission” branch accommodates all the MIB definitions that deals with information transmission (X.25, PPP, RS232, SONET, ISDN, IEEE 802,3, IEEE 802,5, FDDI...)
- ❑ The "at" (ARP Table) branch was replaced by an extension of the group of IP.
- ❑ The EGP (External Gateway protocol) branch is no longer used as the EGP protocol nowadays does not have any importance.
- ❑ Many further MIB modules have been registered under the " mib-2" node. The assignment of the registration numbers is delegated to the Internet Assigned Numbers Authority (IANA).
- ❑ These days it would be good to introduce a certain modularity in the MIB so that different branches could be updated independently.

Further MIBs: Transmission [1/5]

| MIB Description | RFC |
|--------------------------------------|------|
| IEEE 802.3 Repeater Devices | 2108 |
| Data Link Switching | 2024 |
| IEEE 802.5 | 1748 |
| ATM | 1695 |
| SMDS | 1694 |
| Ethernet | 1650 |
| Frame Relay | 1604 |
| SONET / SDH | 1595 |
| FDDI | 1512 |
| Link Control Protocol of PPP | 1471 |
| Multiprotocol Interconnect over X.25 | 1461 |
| DS3 / E3 | 1407 |
| DS1 / E1 | 1406 |
| Frame Relay DTEs | 1315 |

Further MIBs: Network Layer [2/5]

| MIB Description | RFC |
|-------------------------------|------|
| IP Forwarding Table | 2096 |
| RMON | 1757 |
| RMON Version 2 | 2021 |
| IP Mobility Support | 2006 |
| OSPF Version 2 | 1850 |
| RIP | 1724 |
| BGP Version 4 | 1657 |
| Token Ring extensions to RMON | 1513 |
| Identification MIB | 1414 |
| BGP Version 3 | 1269 |

Further MIBs: Application Layer [3/5]

| MIB Description | RFC |
|------------------|------|
| WWW servers | 2039 |
| RDBMS | 1697 |
| DNS Resolver | 1612 |
| DNS Server | 1611 |
| X.500 Directory | 1657 |
| Mail | 1566 |
| Network Services | 1565 |
| Host Resources | 1514 |

Further MIBs: Hardware Specific [4/5]

| MIB Description | RFC |
|--------------------------------|------|
| Entity | 2037 |
| Printer | 1759 |
| Modem | 1696 |
| Parallel printer-like Hardware | 1660 |
| RS-232-like Hardware | 1659 |
| Character Stream Devices | 1658 |
| UPS | 1628 |

Further MIBs: Vendor Specific [5/5]

| MIB Description | RFC |
|------------------------------|------|
| APPC | 2051 |
| TCP/IPX Connection | 1792 |
| SNA Data Link Control (SDLC) | 1747 |
| AppleTalk | 1742 |
| SNA NAUs | 1666 |
| DECNET Phase IV | 1559 |
| SNMP over IPX | 1420 |
| SNMP over AppleTalk | 1419 |

Relations Between MIBs [1/2]

| | MIB-II | Host | Repeater | Bridge | RMON |
|------------------------------|--------|------|----------|--------|------|
| Interface Statistics | X | | | | |
| IP, TCP & UDP Statistics | X | | | | |
| SNMP Statistics | X | | | | |
| Host Job Counts | | X | | | |
| Host File System Information | | X | | | |
| Link Testing | | | X | X | |
| Network Traffic Statistics | | | X | X | X |
| Address Tables | | | X | | X |
| Host Statistics | | | X | | X |

Relations Between MIBs [2/2]

| | MIB-II | Host | Repeater | Bridge | RMON |
|-------------------------------|--------|------|----------|--------|------|
| Historical Statistics | | | | X | |
| Spanning Tree Performance | | | X | | |
| Wide Area Link Performance | | | X | | |
| Thresholds for any variable | | | | X | |
| Configurable Statistics | | | | X | |
| Traffic Matrix with all Nodes | | | | X | |
| 'Host Top N' Information | | | | | X |
| Packet/Protocol Analysis | | | | | X |
| Distributed Logging | | | | X | |

2.4 Simple Network Management Protocol Version 1

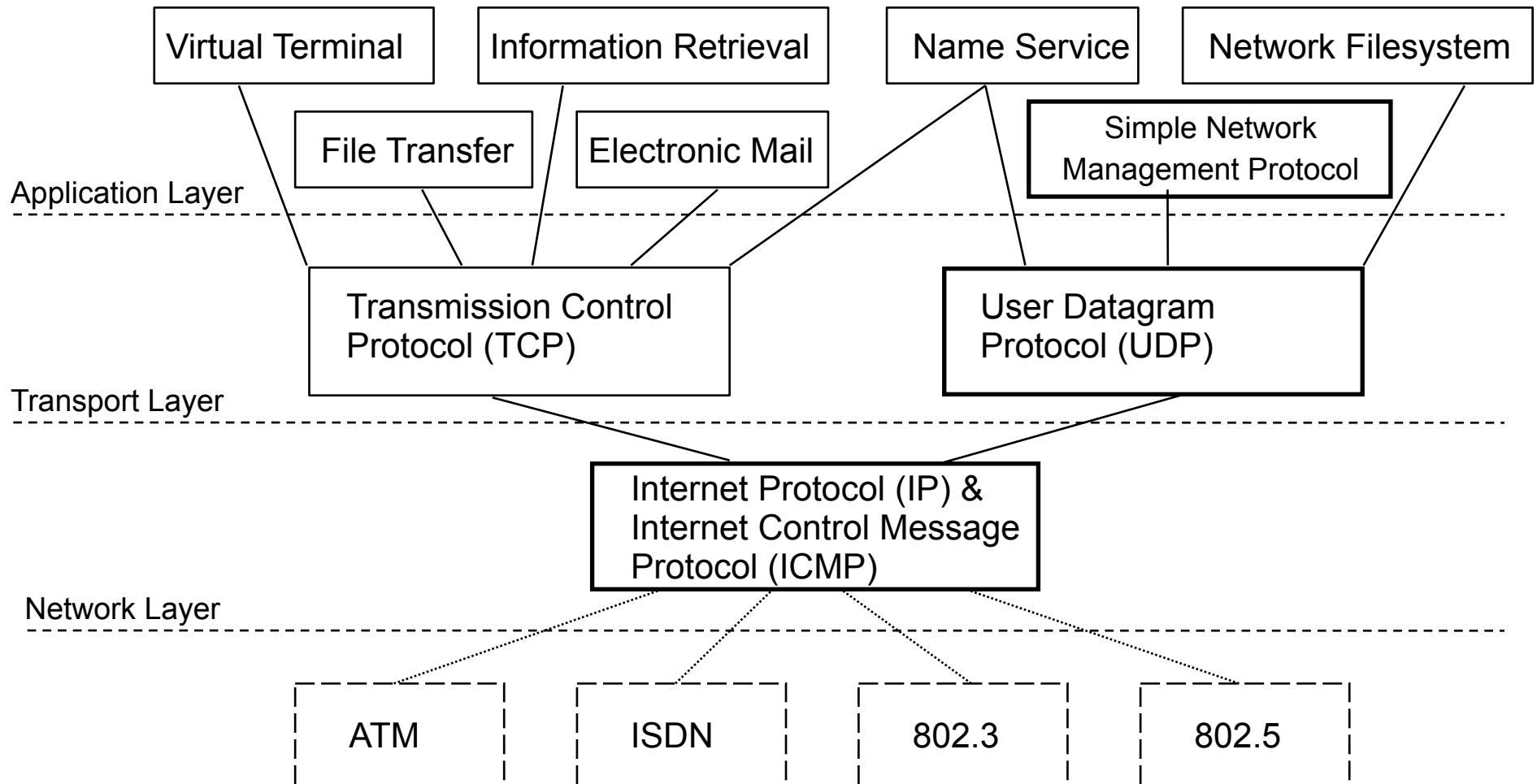

Lexicographical Ordering

- ❑ MIB instances are arranged in the MIB according to their lexicographical ordering.
- ❑ The ordering is determined by the value of the object identifier that identify the instance.
- ❑ The SNMP log uses the lexicographical order, in order to read (walk) conceptual tables or unknown MIBs.

Example of Lexicographical Ordering

| Object Identifier: | Value: | Object Identifier | Value : |
|--------------------|---------------|-------------------|---------|
| 1.1.0 | 10.1.2.3 | 1.3.1.2.4 | 7 |
| 1.2.1.0 | "FilterFresh" | 1.3.1.2.5 | 8 |
| 1.2.2.0 | 54321 | 1.3.1.2.6 | 9 |
| 1.3.1.1.1 | 1 | 1.3.1.3.1 | 2 |
| 1.3.1.1.2 | 2 | 1.3.1.3.2 | 3 |
| 1.3.1.1.3 | 3 | 1.3.1.3.3 | 2 |
| 1.3.1.1.4 | 4 | 1.3.1.3.4 | 2 |
| 1.3.1.1.5 | 5 | 1.3.1.3.5 | 3 |
| 1.3.1.1.6 | 6 | 1.3.1.3.6 | 3 |
| 1.3.1.2.1 | 2 | | |
| 1.3.1.2.2 | 3 | | |
| 1.3.1.2.3 | 5 | | |

- ❑ With this ordering the conceptual table structure is lost as the walk output is a list and no longer a table.
- ❑ the SNMP protocol operates only on this arranged list.

SNMPv1 protocol operations (RFC 1157)

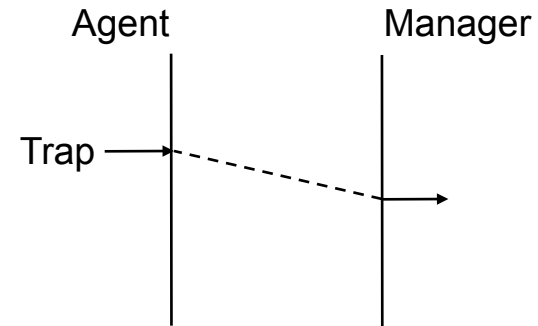
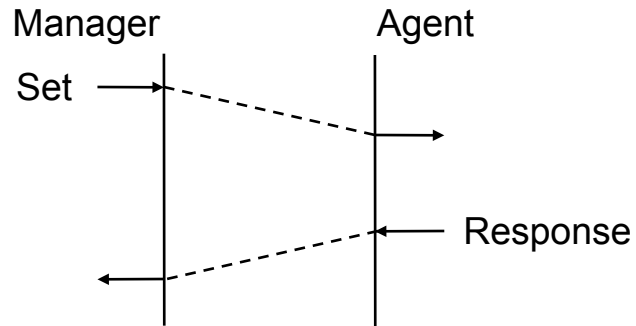
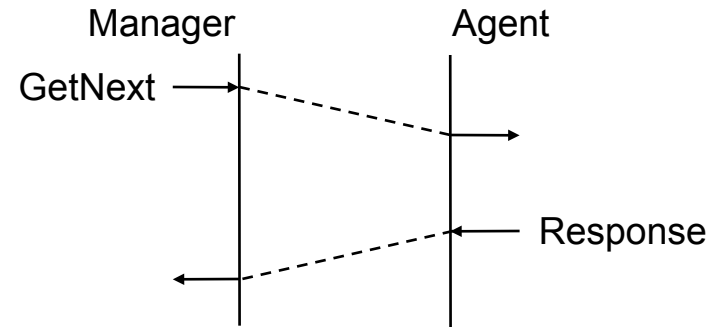
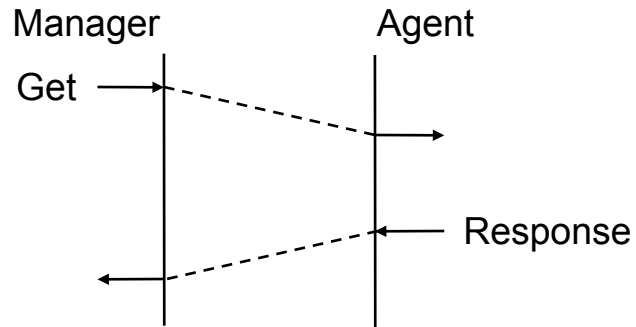

Note: the SNMP protocol can only exchange (a list of) scalars.

SNMPv1 Message Format

SNMP message:

| | | |
|---------|-----------|----------|
| version | community | SNMP PDU |
|---------|-----------|----------|

GetRequest, GetNextRequest, SetRequest:

| | | | | |
|----------|------------|---|---|-------------------|
| PDU type | request-id | 0 | 0 | variable-bindings |
|----------|------------|---|---|-------------------|

GetResponse:

| | | | | |
|----------|------------|--------------|-------------|-------------------|
| PDU type | request-id | error-status | error-index | variable-bindings |
|----------|------------|--------------|-------------|-------------------|

Trap:

| | | | | | | |
|----------|------------|---------|---------|----------|-----------|-----|
| PDU type | enterprise | address | generic | specific | timestamp | vbs |
|----------|------------|---------|---------|----------|-----------|-----|

variable-bindings:

| | | | | | | |
|-------------------|--------------------|-------------------|--------------------|-----|-------------------|--------------------|
| name ₁ | value ₁ | name ₂ | value ₂ | ... | name _n | value _n |
|-------------------|--------------------|-------------------|--------------------|-----|-------------------|--------------------|

SNMPv1 Get Operation

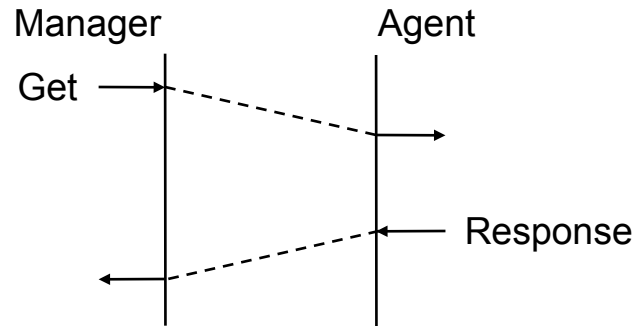

- ❑ The Get operation can be used for reading one or more variables.
- ❑ Possible errors when processing a GET operation:
 - ↳ noSuchName the requested instance does not exist or is not a leaf.
 - ↳ tooBig the result of the request does not fit not into the response (UDP).
 - ↳ genErr any other error occurred.
- ❑ In the case of several errors occurred, only one error is signaled as error-index and error-status are unique in the PDU.

Example of Get Operation

- ❑ `Get(1.1.0)`
`Response(noError@0, 1.1.0=10.1.2.3)`
- ❑ `Get(1.2.0)`
`Response(noSuchName@1, 1.2.0)`
- ❑ `Get(1.1)`
`Response(noSuchName@1, 1.1)`
- ❑ `Get(1.1.0, 1.2.2.0)`
`Response(noError@0, 1.1.0=10.1.2.3, 1.2.2.0=54321)`
- ❑ `Get(1.3.1.1.4, 1.3.1.3.4)`
`Response(noError@0, 1.3.1.1.4=4, 1.3.1.3.4=2)`
- ❑ `Get(1.1.0, 1.2.2.0, 1.1)`
`Response(noSuchName@3, 1.1.0, 1.2.2.0, 1.1)`

SNMPv1 GetNext Operation

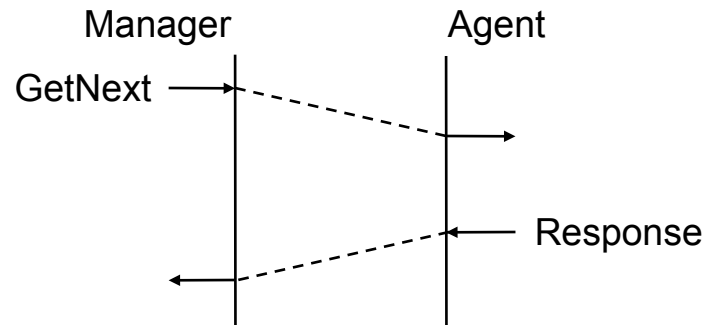

- ❑ It retrieves the object name and the value of the next instance. This operation is used to discover MIB structures and read tables.
- ❑ The GetNext operation allows MIB instances to be read in accordance to the lexicographical order.
- ❑ Using multiple/successive GetNext operations it is possible to read the complete MIB without knowing its structure.
- ❑ Possible errors when processing a GetNext Operation:
 - ↳ noSuchName the requested instance does not exist (= end of MIB).
 - ↳ tooBig the result of the request does not fit not into the response (UDP).
 - ↳ genErr any other error occurred.

Example of GetNext Operation

- ❑ `GetNext(1.1.0)`
`Response(noError@0, 1.2.1.0=FilterFresh)`
- ❑ `GetNext(1.2.1.0)`
`Response(noError@0, 1.2.2.0=54321)`
- ❑ `GetNext(1.1)`
`Response(noError@0, 1.1.0=10.1.2.3)`
- ❑ `GetNext(1.3.1.1.1)`
`Response(noError@0, 1.3.1.1.2=2)`
- ❑ `GetNext(1.3.1.1.6)`
`Response(noError@0, 1.3.1.2.1=2)`
- ❑ `GetNext(1.3.1.1.1, 1.3.1.2.1, 1.3.1.3.1)`
`Response(noError@0, 1.3.1.1.2=2, 1.3.1.2.2=3, 1.3.1.3.2=3)`

SNMPv1 Set Operation

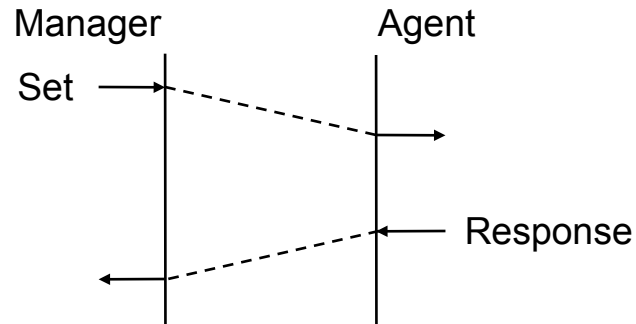

- ❑ The Set Operation writes values in one or more MIB instances.
- ❑ The Set Operation is atomic.
- ❑ With the help of the set operation new MIB instances can also be created, if the MIB definition permits (there is no standard procedure defined in SNMPv1 for instance creation).
- ❑ Possible errors when processing a Set operation:
 - ↳ noSuchName the requested instance does not exist and cannot be created.
 - ↳ badValue the specified value is of wrong type.
 - ↳ tooBig the result of the request does not fit not into the response (UDP).
 - ↳ genErr any other error occurred.
- The error code readOnly is also defined, but not usually used!

Example of Set Operation

- ❑ `Set(1.2.1.0=HotJava)`
`Response(noError@0, 1.2.1.0=HotJava)`

- ❑ `Set(1.1.0=foo.bar.com)`
`Response(badValue@1, 1.1.0=foo.bar.com)`

- ❑ `Set(1.1.1=10.2.3.4)`
`Response(noSuchName@1, 1.1.1=10.2.3.4)`

- ❑ `Set(1.2.1.0=HotJava, 1.1.0=foo.bar.com)`
`Response(badValue@2, 1.2.1.0=HotJava, 1.1.0=foo.bar.com)`

- ❑ `Set(1.3.1.1.8=7, 1.3.1.2.7=2, 1.3.1.3.7=3)`
`Response(noError@0, 1.3.1.1.8=7, 1.3.1.2.7=2, 1.3.1.3.7=3)`

SNMPv1 Trap Operation

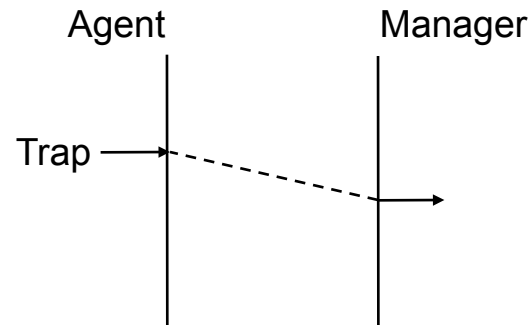

NOTE:

- The only operation Agt ->Mgr
- Unsolicited operation

- ❑ With the trap operation and agent can emit an event and inform a manager. Note: a manager can be configured to discard traps!
- ❑ The receipt of a trap operation is not acknowledged thus is unreliable as it can be lost during the transfer.
- ❑ The production of traps can lead to so-called trap storms, if e.g. after a power failure all devices want to display the restart at the same time.
- ❑ Agents can be normally configured with the IP addresses of hosts where traps can be dispatched. However there is no standard technique in SNMPv1 for such agent configuration. Usually a configuration file (not the MIB) is used.
- ❑ Although if traps are used, polling is still necessary (for instance the agent might be down)

Example of SNMPv1 Trap Operation

- ❑ ColdStart
Trap(generic=0, specific=0)
- ❑ WarmStart
Trap(generic=1, specific=0)
- ❑ LinkDown
Trap(generic=2, specific=0, 1.3.6.1.2.1.2.2.1.1.2=2)
- ❑ LinkUp
Trap(generic=3, specific=0, 1.3.6.1.2.1.2.2.1.1.2=2)
- ❑ AuthenticationFailure
Trap(generic=4, specific=0)
- ❑ EnterpriseSpecific (QMS, qmsPtrErrorMsg)
Trap(generic=6, specific=1, enterprise=1.3.6.1.4.1.480,
1.3.6.1.4.1.480.2.1.1.1=out of paper)

Agent MIB Implementation

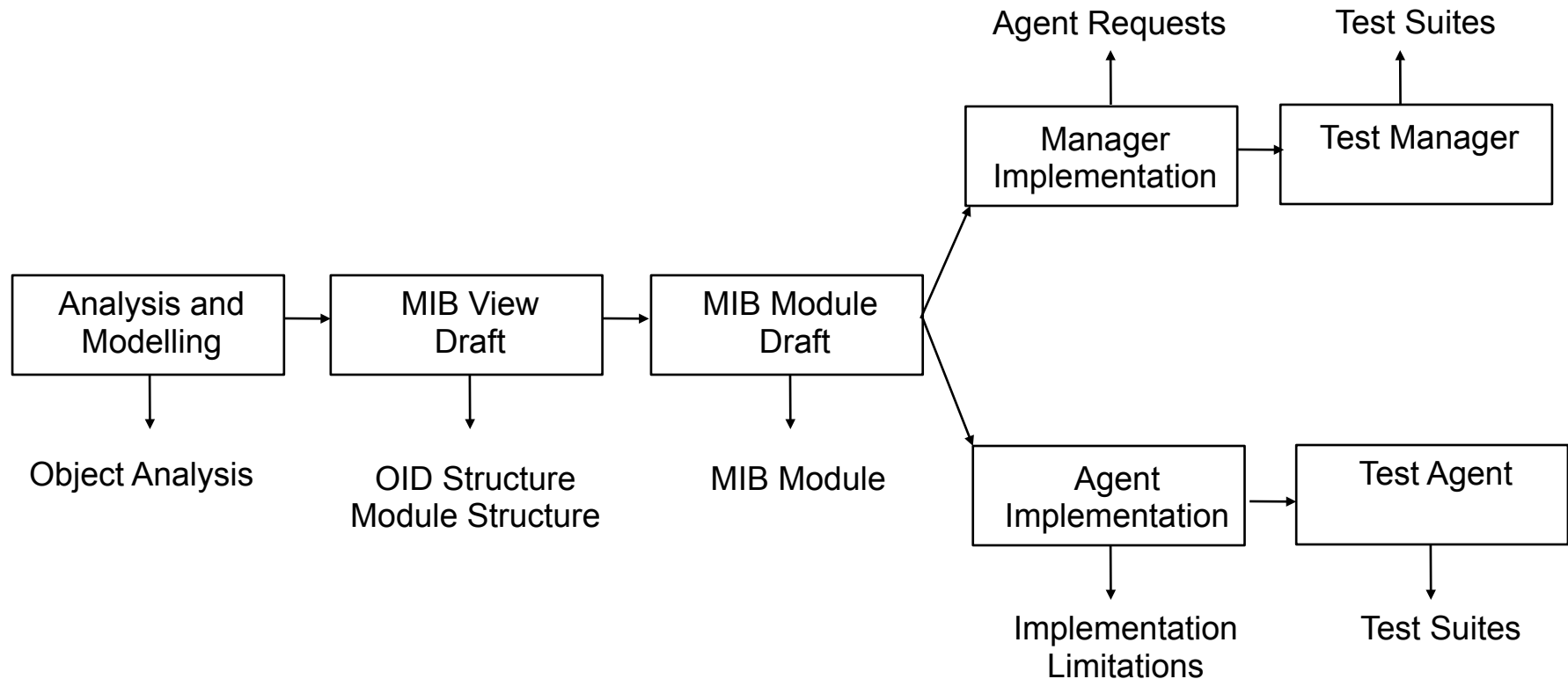

- ❑ It is possible for have several iterative phases for the MIB definitions until it is in draft status.
- ❑ MIB definitions cannot however be further changed, if they were released.

2.5 Simple Network Management Protocol Version 2c

- There are some variants of of SNMP Version 2:
 - ↳ SNMPv2p
SNMPv2 version with party-based security model, historical
 - ↳ SNMPv2c
SNMPv2 with trivial community-based security model, experimental
 - ↳ SNMPv2u
SNMPv2 with a user-based security model, historical
 - ↳ SNMPv2*
SNMPv2 with security and administration model, historical
- The term SNMPv2 is ambiguous. SNMPv2c found some spreading, although IETF has never standardized it.
- Work on a solution of the security problems has blocked improvements of other protocol characteristics (too) for a long time.

SNMPv2c protocol operations (RFC 1905)

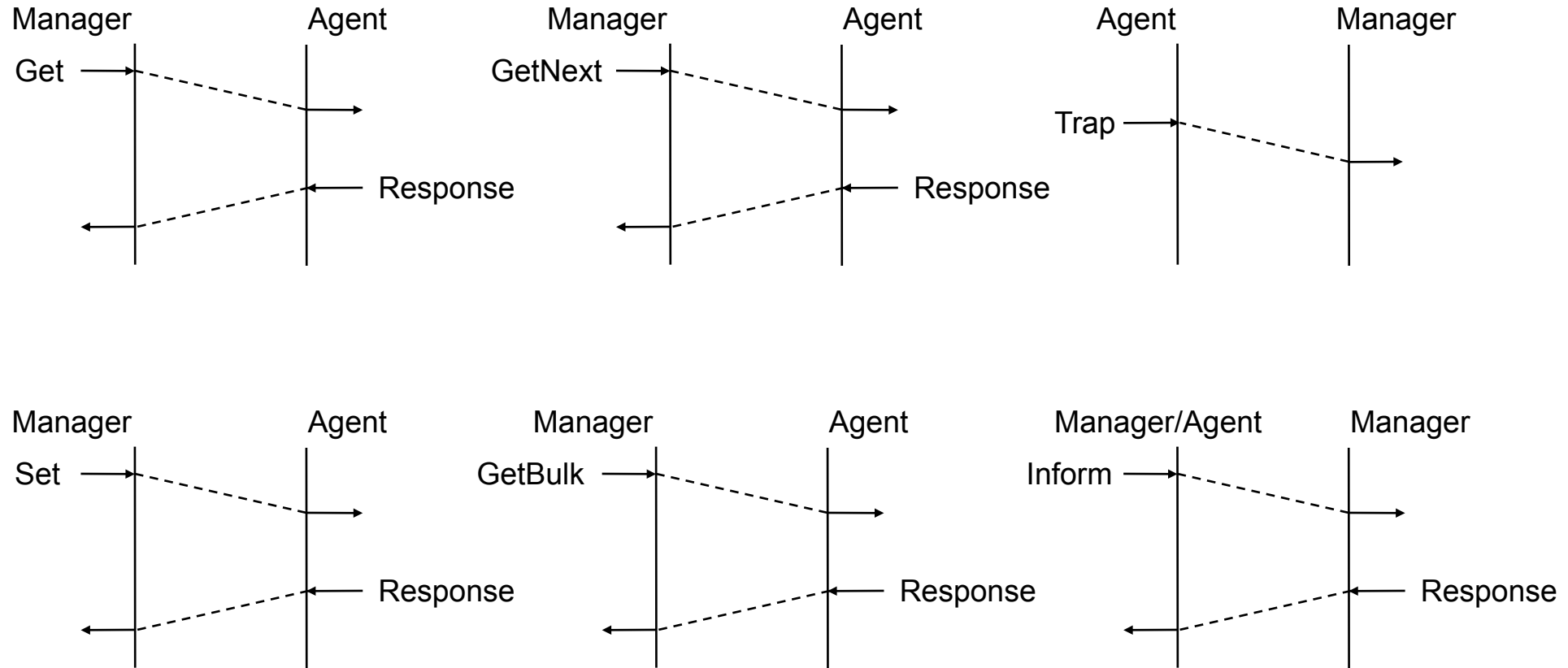

SNMPv2c Message Format

SNMP message:

| | | |
|---------|-----------|----------|
| version | community | SNMP PDU |
|---------|-----------|----------|

GetRequest, GetNextRequest, SetRequest, Trap, InformRequest:

| | | | | |
|----------|------------|---|---|-------------------|
| PDU type | request-id | 0 | 0 | variable-bindings |
|----------|------------|---|---|-------------------|

GetResponse:

| | | | | |
|----------|------------|--------------|-------------|-------------------|
| PDU type | request-id | error-status | error-index | variable-bindings |
|----------|------------|--------------|-------------|-------------------|

GetBulkRequest:

| | | | | |
|----------|------------|----------|----------|-------------------|
| PDU type | request-id | non-reps | max-reps | variable-bindings |
|----------|------------|----------|----------|-------------------|

variable-bindings:

| | | | | | | |
|-------------------|--------------------|-------------------|--------------------|-----|-------------------|--------------------|
| name ₁ | value ₁ | name ₂ | value ₂ | ... | name _n | value _n |
|-------------------|--------------------|-------------------|--------------------|-----|-------------------|--------------------|

SNMPv2 Exceptions (RFC 1905)

| SNMPv2 Exception | SNMPv1 Status | Used by |
|------------------|---------------|------------------|
| noSuchObject | noSuchName | Get |
| noSuchInstance | noSuchName | Get |
| endOfMibView | noSuchName | GetNext, GetBulk |

- ❑ Exceptions allow instance access errors to be signaled to MIB authorities, without causing the whole operation to fail (as happened in SNMPv1).

- ❑ Example:

```
Get(1.1.0, 1.1.1, 1.2.0)
```

```
Response(noError@0, 1.1.0=10.1.2.3, 1.1.1=noSuchInstance,  
1.2.0=noSuchObject)
```

```
GetNext(1.1, 1.5.42)
```

```
Response(noError@0, 1.1.0=10.1.2.3, 1.5.42=endOfMibView)
```

SNMPv2c Get and GetNext Operations

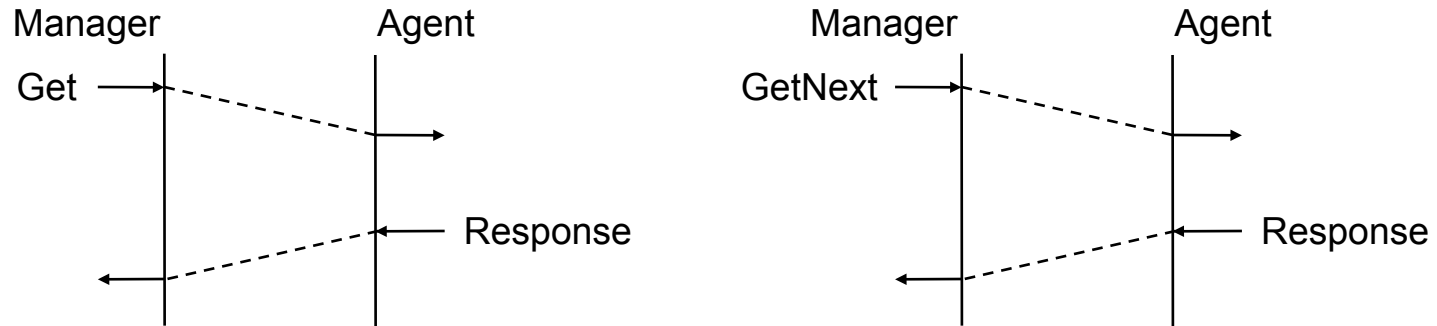

- ❑ Not existing MIB instances produce an exception and not an error.
- ❑ Similar to the equivalent SNMPv1 operations.

SNMPv2c Set Operation

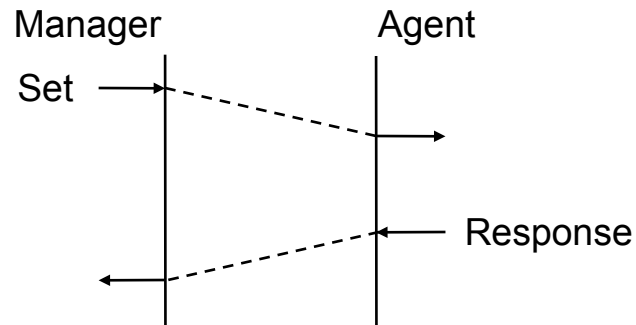

- ❑ There are 14 possible error codes during processing of set operations:

| | | |
|---------------------|-------------------|------------------|
| wrongValue | wrongEncoding | wrongType |
| wrongLength | inconsistentValue | noAccess |
| notWritable | noCreation | inconsistentName |
| resourceUnavailable | commitFailed | undoFailed |

- ❑ There are two more error codes that have been defined but not really used:
readOnly, authorizationError
- ❑ No support of error codes that depend on the object type.

SNMPv2c GetBulk Operation

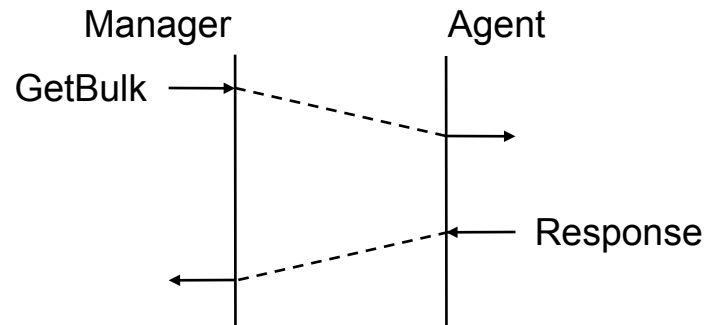

- ❑ An extension of the GetNext operation:
 - ↳ It returns the first N elements (non repetition) of the varbind list treated as normal GetNext operations.
 - ↳ The following items of the varbind list treated as repeated Get Next operation, whereby M (max repetition) indicates the max number of repetitions.

- ❑ The GetBulk operation is similar to the GetNext operation on the lexicographical arranged list of the MIB instances and has therefore no knowledge of table boundaries.

Example of the GetBulk Operation

- ❑ `GetBulk(non-repeaters=0, max-repetitions=4, 1.1)`
`Response(noError@0, 1.1.0=10.1.2.3, 1.2.1.0=FilterFresh,`
`1.2.2.0=54321, 1.3.1.1.1=1)`
- ❑ `GetBulk(non-repeaters=1, max-repetitions=2`
`1.2.2.0, 1.3.1.1, 1.3.1.2, 1.3.1.3)`
`Response(noError@0, 1.2.2.0=54321,`
`1.3.1.1.1=1, 1.3.1.2.1=2, 1.3.1.3.1=2,`
`1.3.1.1.2=2, 1.3.1.2.2=3, 1.3.1.3.2=3)`
- ❑ Without knowledge about the length of a table it is difficult for the manager to select a suitable number for max repetitions:
 - ↳ if max-repetitions is too small, then there is no efficiency increase of GetBulk with respect to the GetNext operation .
 - ↳ if max-repetitions is too large, then a large number of unnecessary instances are read .
- The agent can possibly produce a response, which can either get lost in large/busy networks or not be processed at all by the manager (this causes the manager to retransmit the request).
- If max repetitions is large and reading the MIB instances is time-consuming, agents can receive multiple times the manager's request (e.g. due to retransmission) thus blocking the agent for some time.

SNMPv2c Trap Operation

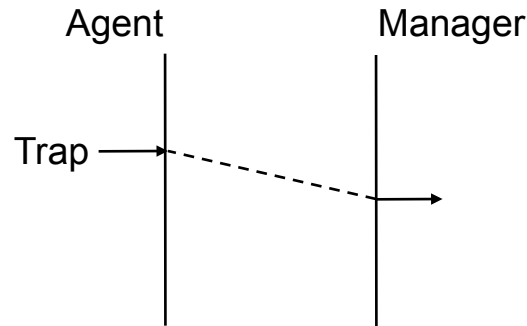

- ❑ It corresponds logically to the SNMPv1 Trap operation.
- ❑ Trap specific information (sysUpTime, trapType) is accommodated in the varbind list.
- ❑ Trap types are indicated by Object Identifier and not by a pair of numbers (generic, specific) as in SNMPv1.

SNMPv1 vs. SNMPv2c Traps

- ❑ In SNMPv2 MIBs may now include NOTIFICATION-TYPE macros.
- ❑ SNMPv1 Trap

```
myLinkDown TRAP-TYPE
```

```
    ENTERPRISE myEnterprise
```

```
    VARIABLES { ifIndex }
```

```
    DESCRIPTION
```

```
        "A myLinkDown trap signifies that the sending SNMP application
        entity recognises a failure in one of the communications links
        represented in the agent's configuration."
```

```
 ::= 2
```

- ❑ SNMPv2 Trap

```
linkUp NOTIFICATION-TYPE
```

```
OBJECTS { ifIndex }
```

```
STATUS current
```

```
DESCRIPTION
```

```
    "A linkUp trap means that the entity has detected that the ifOperStatus
    object has changed to Up"
```

```
 ::= { snmpTraps 4 }
```

SNMPv2c Inform Operation

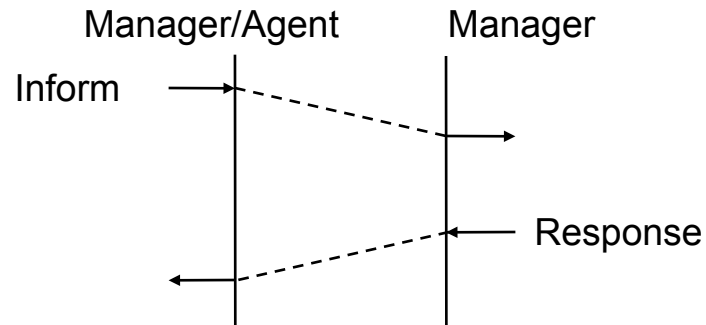

- ❑ The structure of the PDU corresponds to a SNMPv2 Trap PDU.
- ❑ It allows (new) managers to talk each other (SNMPv1 limited interaction to agent-manager or vice-versa).
- ❑ The receipt of a Inform message is acknowledged with a Response message.
- ❑ Example:
`Inform(1.2.2.0=54321, 1.4.1.0=1.4.2.43,
1.3.1.2.2=16, 1.3.1.3.2=3)`
`Response(noError@0, 1.2.2.0=54321, 1.4.1.0=1.4.2.43,
1.3.1.2.2=16, 1.3.1.3.2=3)`

SNMPv2c and SNMPv1 Error Codes

| SNMPv2 | SNMPv1 | Comment |
|---------------------|------------|--------------------------------------|
| noError | noError | all operations |
| tooBig | tooBig | Get, GetNext, Set, Inform |
| noSuchName | noSuchName | Get, GetNext, Set (only with SNMPv1) |
| badValue | badValue | Set (only with SNMPv1) |
| readOnly | readOnly | not used |
| genErr | genErr | Get, GetNext, GetBulk, Set |
| wrongValue | badValue | Set (only with SNMPv2c) |
| wrongEncoding | badValue | Set (only with SNMPv2c) |
| wrongType | badValue | Set (only with SNMPv2c) |
| wrongLength | badValue | Set (only with SNMPv2c) |
| inconsistentValue | badValue | Set (only with SNMPv2c) |
| noAccess | noSuchName | Set (only with SNMPv2c) |
| notWritable | noSuchName | Set (only with SNMPv2c) |
| noCreation | noSuchName | Set (only with SNMPv2c) |
| inconsistentName | noSuchName | Set (only with SNMPv2c) |
| resourceUnavailable | genErr | Set (only with SNMPv2c) |
| commitFailed | genErr | Set (only with SNMPv2c) |
| undoFailed | genErr | Set (only with SNMPv2c) |
| authorizationError | noSuchName | Not used |

SNMP v2 vs SNMP v1

- ❑ Improved Performance via the Get-Bulk PDU.
- ❑ Definition of additional datatypes and formalisms based on implementation experience of SNMPv1 agents/managers.
- ❑ Transport Service Independence: mappings for SNMPv2 have been defined for several transports and not for just UDP (TCP is on the way!).
- ❑ Redefined the Trap PDU:
 - ↳ It has the same format of the other PDUs
 - ↳ It may be sent to zero, one or many managers

2.6 SNMP V3

- ❑ Design goals of SNMPv3:
 - ↳ Issue of secure SET protocol operations.
 - ↳ Definition (hopefully) of a long-living architecture model
 - ↳ Support of cheap simple and more expensive complex implementations (scalability).
 - ↳ Independence of the standards
 - ↳ Use of existing material (mostly MIBs) when possible (design reuse)
 - ↳ SNMP is to remain as simply as possible

- ❑ Several (commercial and open source) implementation available.

- ❑ Spreading in real networks still relatively small (most network devices still use SNMPv1).

Architectural Model of SNMPv3 (RFC 2571)

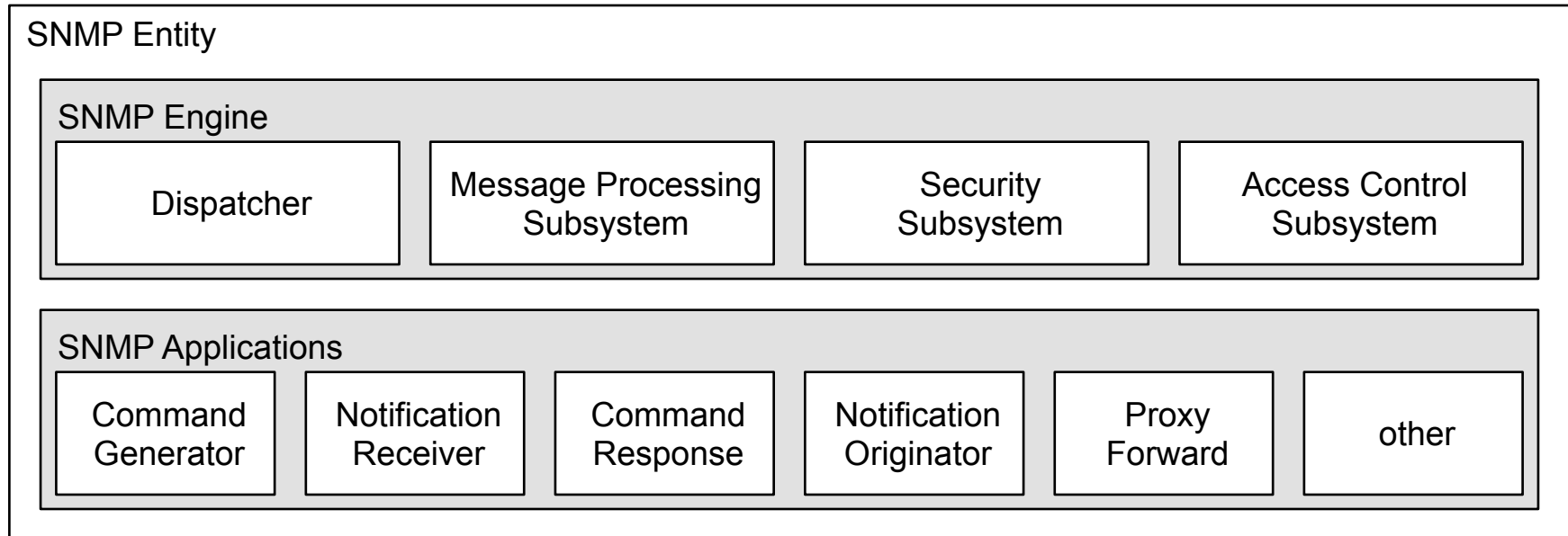

- ❑ The SNMP engine of a SNMP entity consists of several subsystems and a dispatcher.
- ❑ The manager/agent model is replaced by a number of smaller “applications”.
- ❑ The modularity permits incremental advancement of SNMP by means of SNMP Context (RFC 2571)

SNMP Context (RFC 2571)

- ❑ A context is a quantity of management information that a SNMP Entity can have accessed to. For each subsystem:
 - ↳ a SNMP-Entity has potentially access to several contexts.
 - ↳ The same information can be present in several contexts.

- ❑ In a management domain an instance of a Managed Objects is uniquely identified by the following items:
 - the identification of the SNMP engines in a SNMP Entity (e.g. „xzy“).
 - the name of the context in a SNMP Entity (e.g. „board1“).
 - the identification of the type of the Managed Objects (e.g. „IF-MIB::ifDescr“).
 - the identification of the Instance (e.g. „1“).

- Note: the identification of an SNMP engine does not have to do anything with their addressing.

SNMPv3 Agent in SNMPv3: Architectural Model

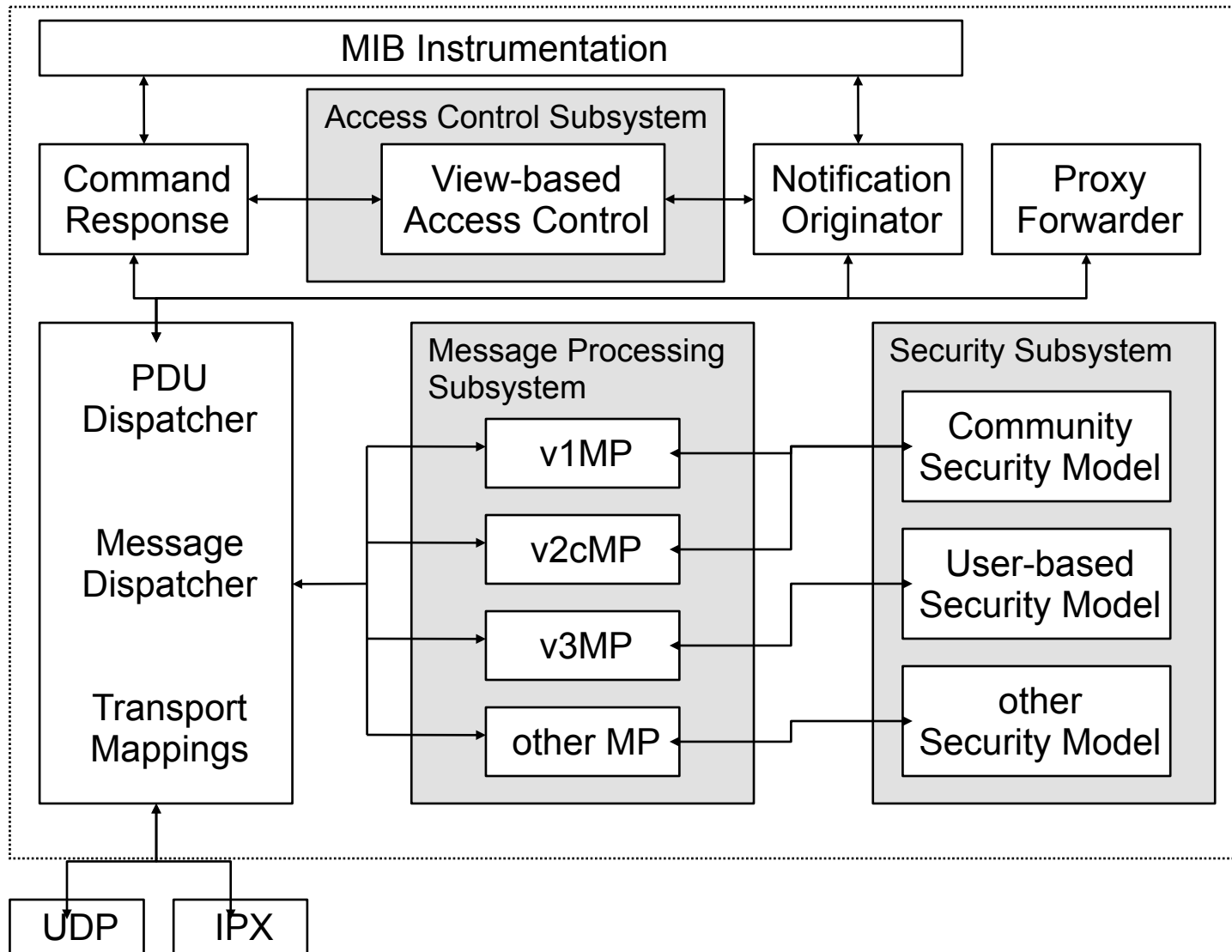

SNMPv3 Message Format (RFC 2572)

SNMPv3Message:

| | | | |
|------------|---------------|----------------------|---------------------|
| msgVersion | msgGlobalData | msgSecurityParameter | msgData (scopedPDU) |
|------------|---------------|----------------------|---------------------|

MsgGlobalData:

| | | | |
|-------|------------|----------|------------------|
| msgID | msgMaxSize | msgFlags | msgSecurityModel |
|-------|------------|----------|------------------|

UsmSecurityParameter:

| | | | | | |
|-------------|----------------|---------------|-------------|---------------|---------------|
| msgEngineID | msgEngineBoots | msgEngineTime | msgUserName | msgAuthParams | msgPrivParams |
|-------------|----------------|---------------|-------------|---------------|---------------|

ScopedPDU:

| | | |
|-----------------|-------------|-------------------------------------|
| contextEngineID | contextName | SNMPv2 PDU (as defined in RFC 1905) |
|-----------------|-------------|-------------------------------------|

- ❑ Security information are in the centre of the message.
- ❑ msgData contain either a ScopedPDU or an encoded ScopedPDU.
- ❑ msgID is used for the association of responses to pending inquiries.
- ❑ msgSecurityParameter depends on msgSecurityModel.

Security Issues

- ❑ How you can find the questions which must be answered when a decision whether an operation has to be performed:
 - Is the received message authentic?
 - Who (requester name) would like to get the operation executed?
 - Which objects are affected by the operation?
 - Which access rights has the requester regarding the objects concerned?
- ❑ Questions 1 and 2 are answered by the measures to the protection of the messages (authentication, encoding).
- ❑ Questions 3 and 4 are answered by a model to the access supervision (Unix-like).

Data Integrity and Authentication

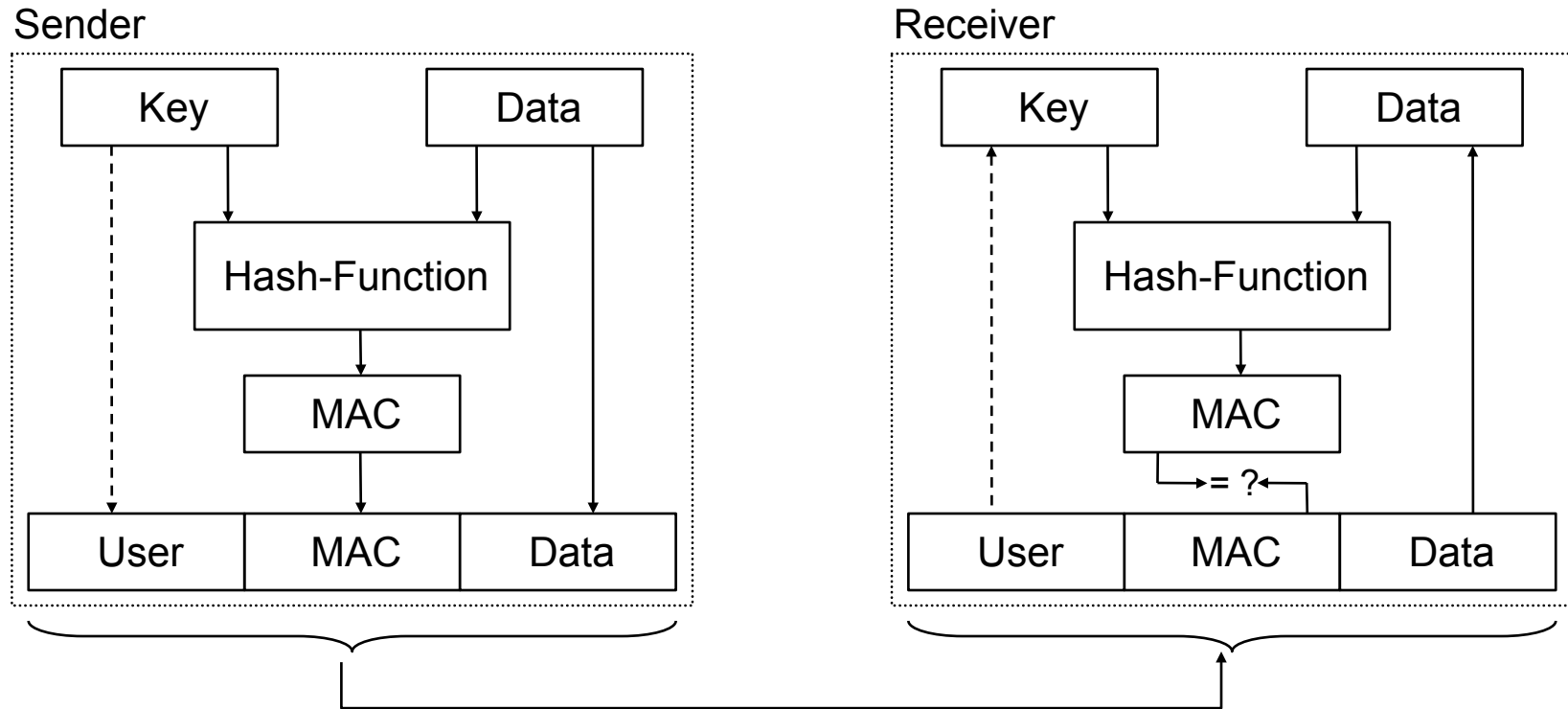

- ❑ Authentication with Message Authentication Code (MAC) is efficient to implement.
- ❑ The Hash function must be cryptographically strong and a "good" MAC producer.
- ❑ The MD5 algorithm (RFC 1321) can be implemented in software with acceptable performance (128 bit digest).
- ❑ The Secure Hash algorithm 1 (SHA-1) is considered at present stronger of MD5 .

Protection Against Repetitions of Old Messages

Authoritative Engine

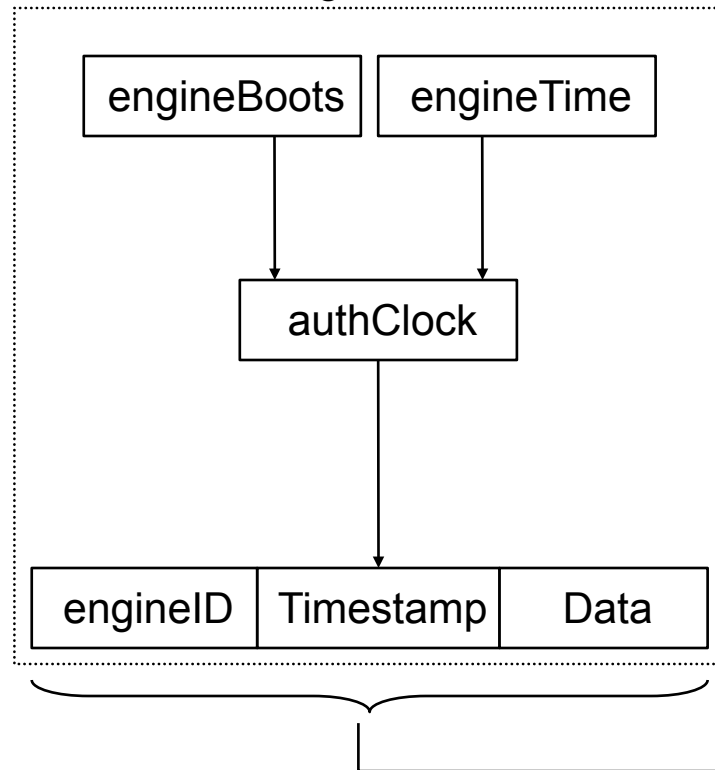

Receiver

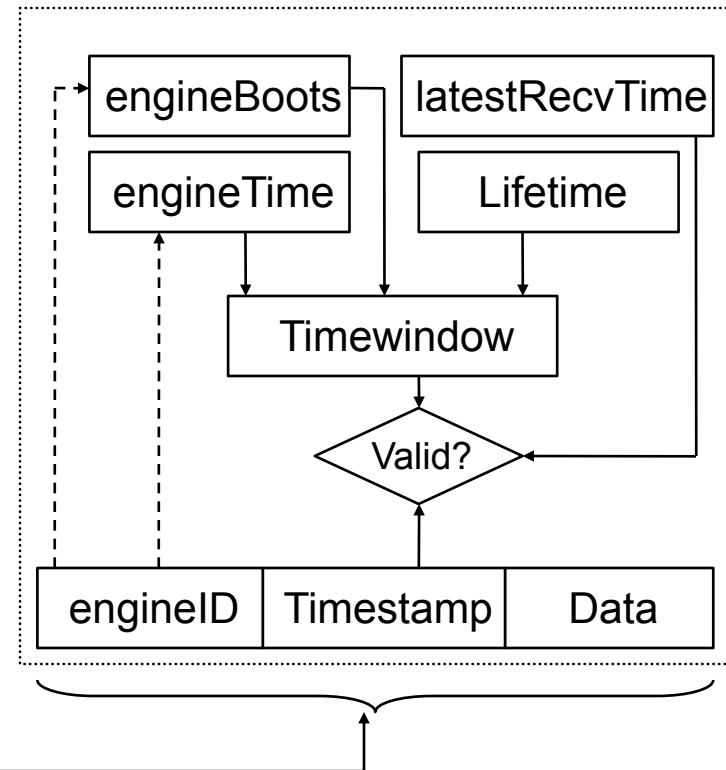

- ❑ A recipient must know the "time-of-day" of the authoritative SNMP engine for the message.
- ❑ If the received message is situated in the validity interval and is "younger" than the last valid message, then the message will become processed and the clocks adapted.
- ❑ Before the beginning of authenticated communication the clocks must be synchronized.

Protection Against Sniffing

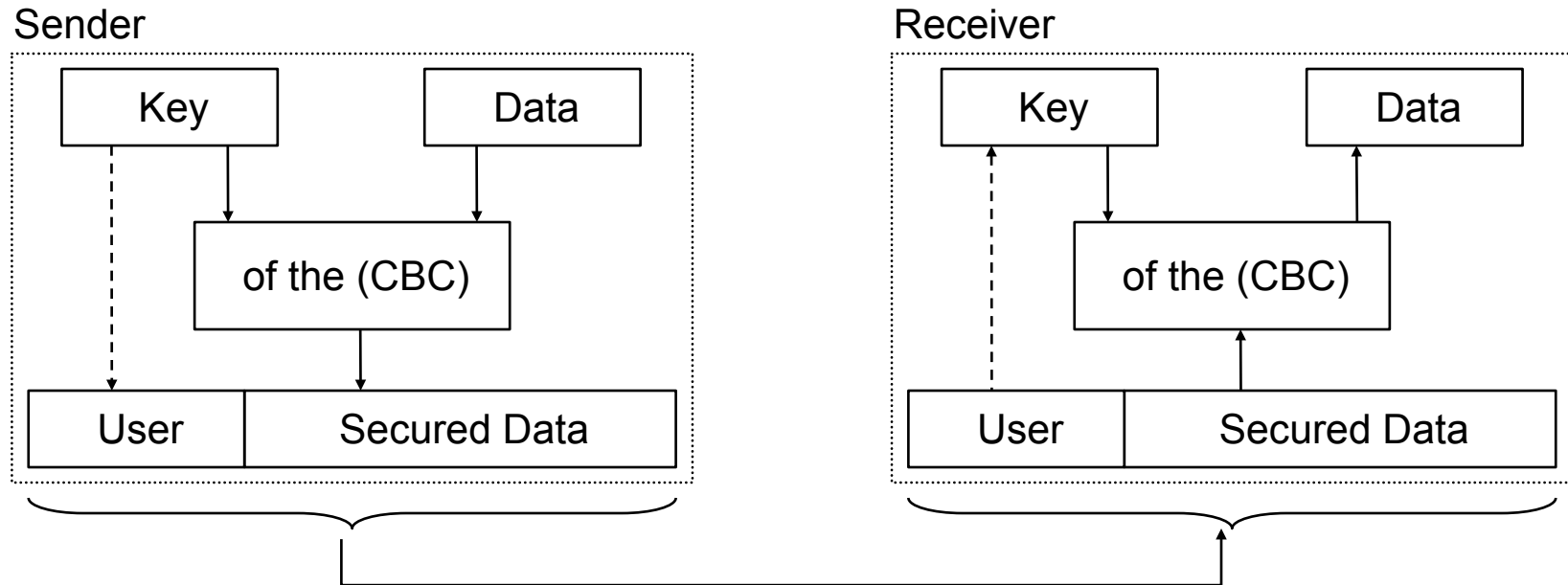

- ❑ For protecting against sniffing the ScopedPDU can be optionally encoded.
- ❑ Data Encryption Standard (of the) in Cipher Block Chaining Modus (CBC) is used for encryption.
- ❑ Encryption is relatively complex and should only be used in area/situations where an encoding is really necessarily.
- ❑ SNMPv3 permits "relatively protected" code modification without encryption (by using message digest).

MIB Views (RFC 2575)

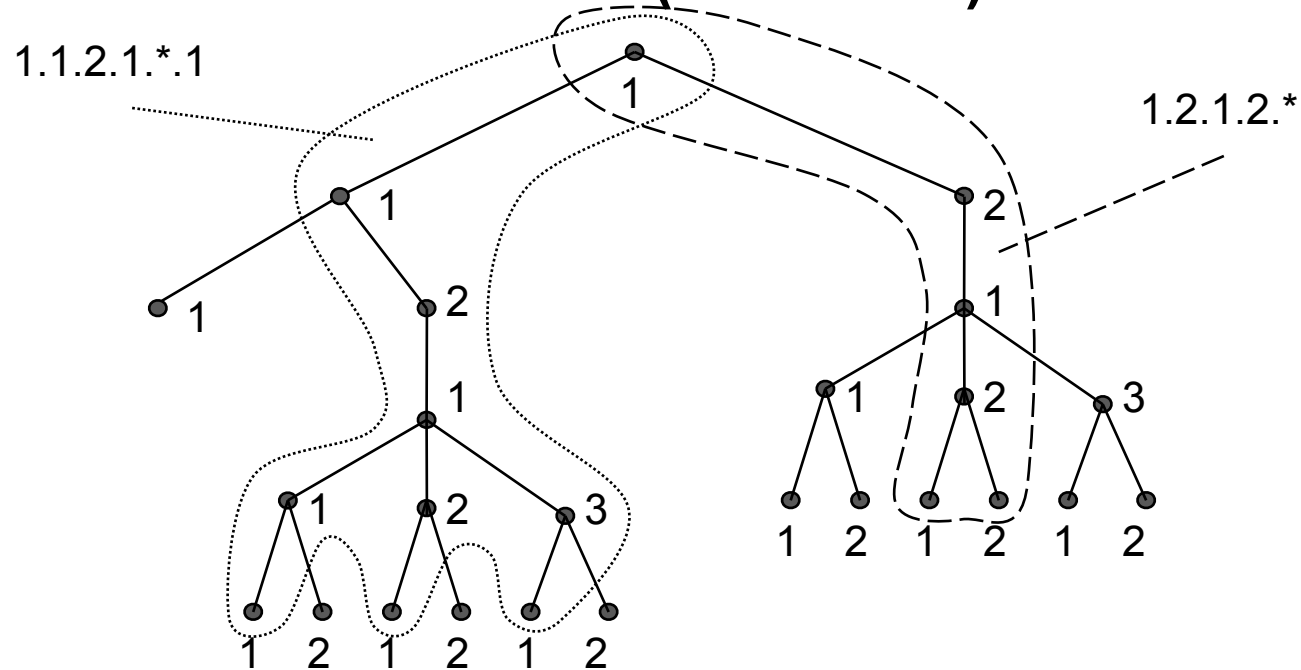

- ❑ A view subtree is the quantity of all MIB objects, which possess common OID prefix.
- ❑ A view tree family is the combination of one view subtree OID prefix with a filter (bitmask), which determines whether an item of the prefix is significant or not.
- ❑ A view is an ordered set of view tree families.
- ❑ It defines the access rights for read view, write view and notify view.

MIB Name Conventions

- ❑ Similar definitions should be registered together in the registration tree.
- ❑ Names of object types should begin the logical grouping with a common prefix, that suggest (e.g. sysDescr, sysUpTime).
- ❑ Names for counter are to be selected in the Plural form.
- ❑ Names of conceptual tables should possess the ending Table (e.g. ifTable).
- ❑ Names of lines of a conceptual table should possess the ending entry (e.g. ifEntry).
- ❑ All items of a conceptual table should use common prefix in the name (e.g. ifType, ifDescr).

Monolithic Agents

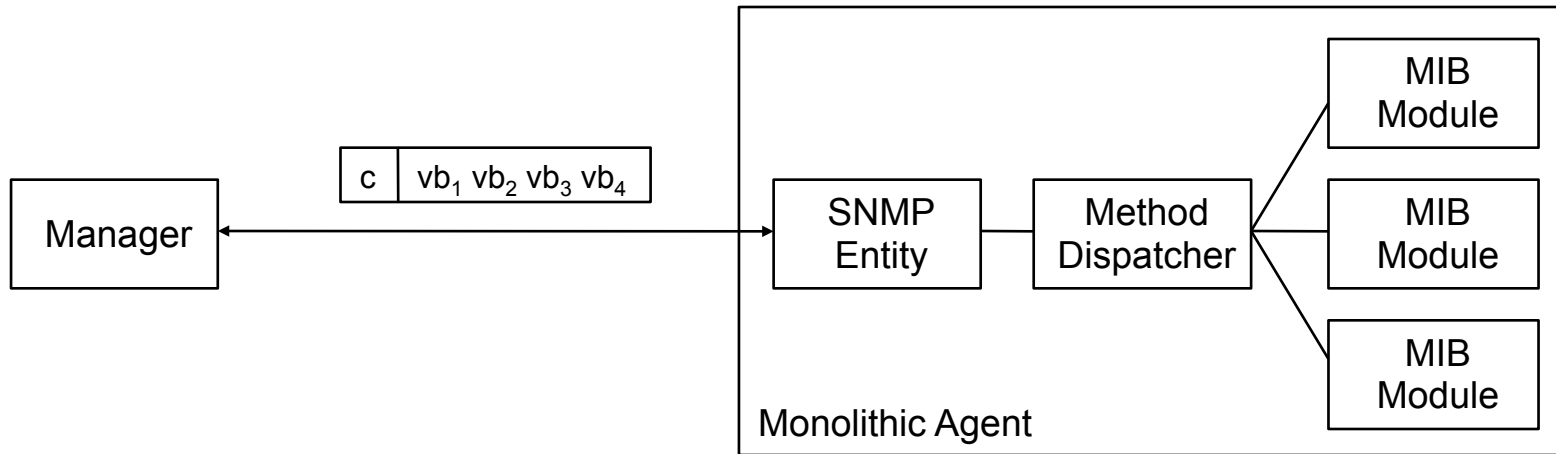

- ❑ A monolithic agent is normally implemented by an individual process which contains the SNMP protocol machine and the MIB instrumentation.
- ❑ The supported MIB modules is determined at compilation time.
- ❑ The method dispatchers is called during processing of SNMP messages, which can either read or modify values from relevant resources.

Proxy-Agents

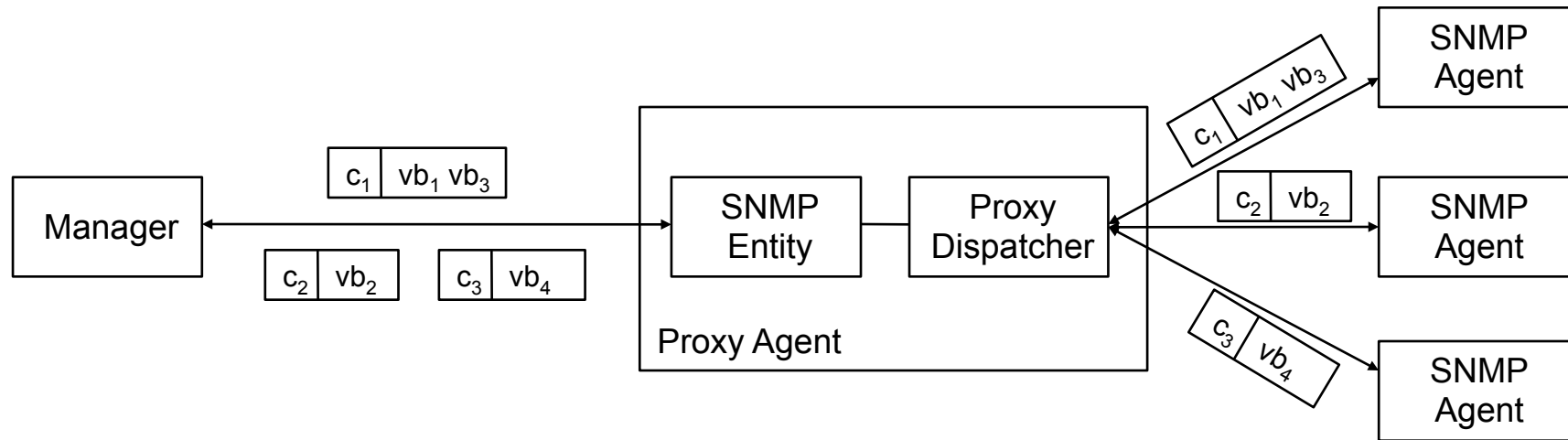

- ❑ SNMP Proxy agents permit managers to access other SNMP agents that are not reachable directly (e.g. behind a firewall) or that are reachable using non IP protocols (e.g. IPX).
- ❑ Management applications must (usually) select the appropriate community string or context in order to enable the proxy to reach the agents (no transparency).
- ❑ Proxy are important for the implementation of firewalls or for conversion between different SNMP protocol versions.

Extensible Agents

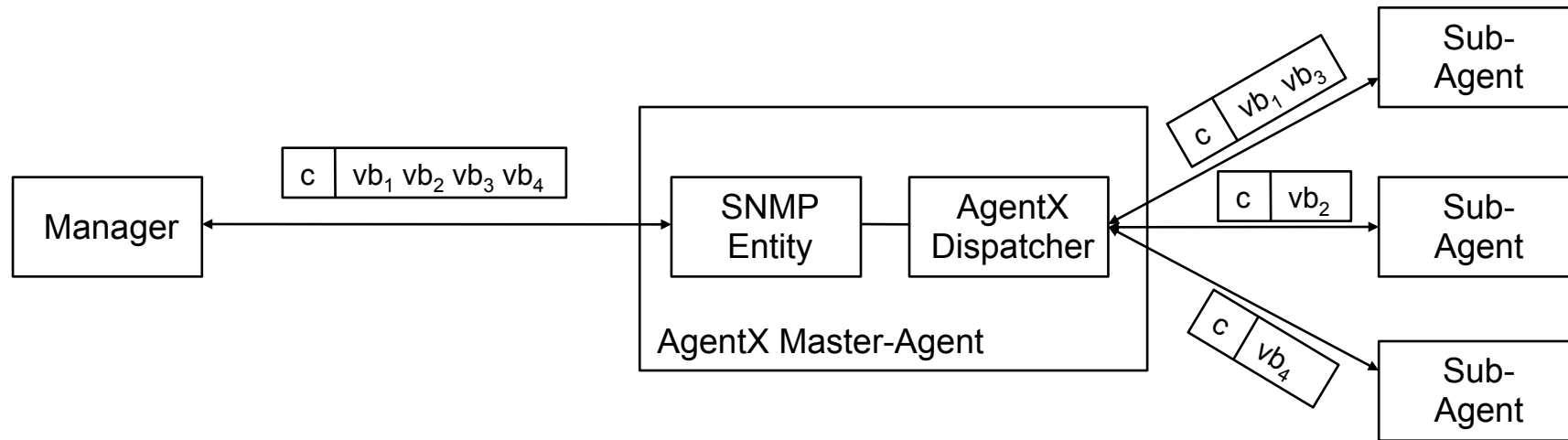

- ❑ Extensible SNMP agents separate the SNMP protocol machine (master agent) from the MIB instrumentation (subagent).
- ❑ MIB modules can be added by starting further subagents dynamically at runtime.
- ❑ Expandable agents are transparent for management applications.
- ❑ A special protocol regulate communications between the master agent and the subagents

AgentX-Protocol Version 1 (RFC 2257)

- ❑ The AgentX protocol is a new standard protocol for the implementation of expandable SNMP agents.

- ❑ AgentX Message Coding:
 - ↳ No ASN.1 coding.
 - ↳ Compact representation of object identifier values by coding repetitive OID prefixes.
 - ↳ Byte order is selected by the subagent (no transformations necessarily, if master agent and subagent on the same system).

- ❑ AgentX Message Transport:
 - ↳ TCP connections to the port 705.
(It is possible to have several AgentX sessions over the same TCP connection)
 - ↳ UNIX Domain Sockets (/var/agentx/master).
 - ↳ Can be likewise used other local (not standardised) IPC mechanisms.

Administrative AgentX Protocol Operations

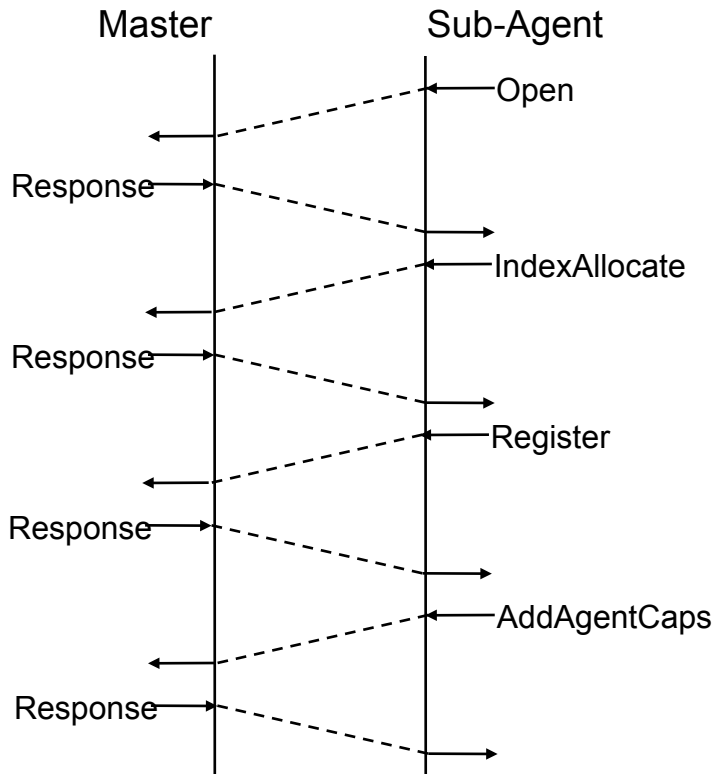

- AgentX Session Establishment
- Index Allocation
- MIB Registration
- Registration of the Agent Capabilities

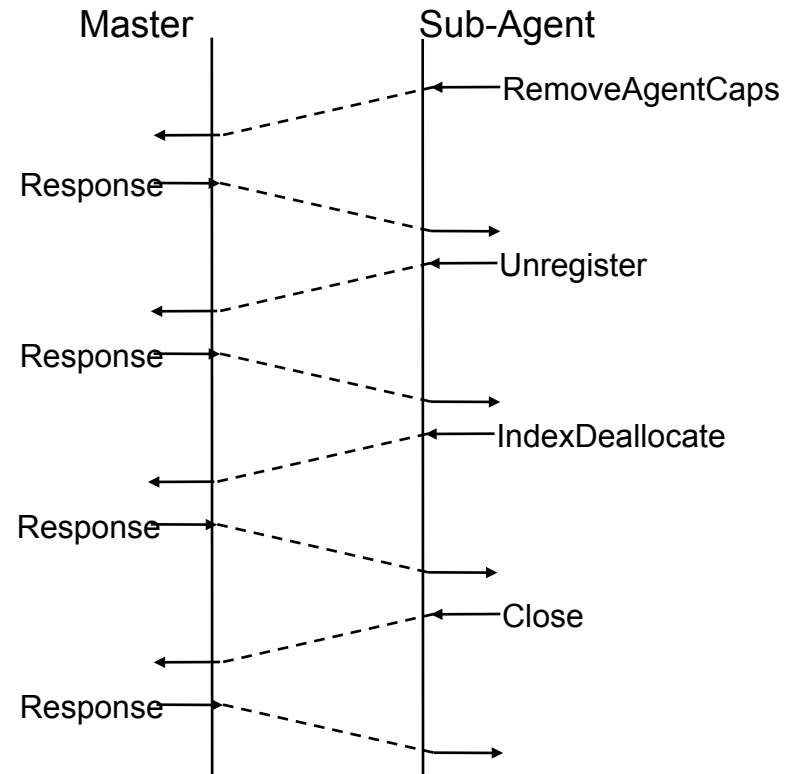

- Deregistration of the Agent Capabilities
- MIB Deregistration
- Free of allocated indexes
- AgentX Session Termination

Index-Allocation, OID Registration, Scoping

- ❑ Index allocation for common tables between subagents:
 - ↳ Allocation of specific (private) indexes.
 - ↳ Allocation of indexes not used at present.
 - ↳ Allocation of indexes no longer in use.

- ❑ OID Registration:
 - ↳ Registration of individual instances (instance level registration)
 - 1.3.6.1.2.1.2.2.1.1.42 (ifIndex.42)
 - 1.3.6.1.2.1.2.2.1.2.42 (ifDescr.42)
 - 1.3.6.1.2.1.2.2.1.3.42 (ifType.42)
 - ↳ Registration of MIB Ranges:
 - 1.3.6.1.2.1.2.2.1.[1-22].42 (ifIndex.42 - ifSpecific.42)

- ❑ Scoping:
 - ↳ AgentX can specify scoping with GetBulk operations (similar to CMIP Scope).

AgentX Protocol Operations for SNMP Operations

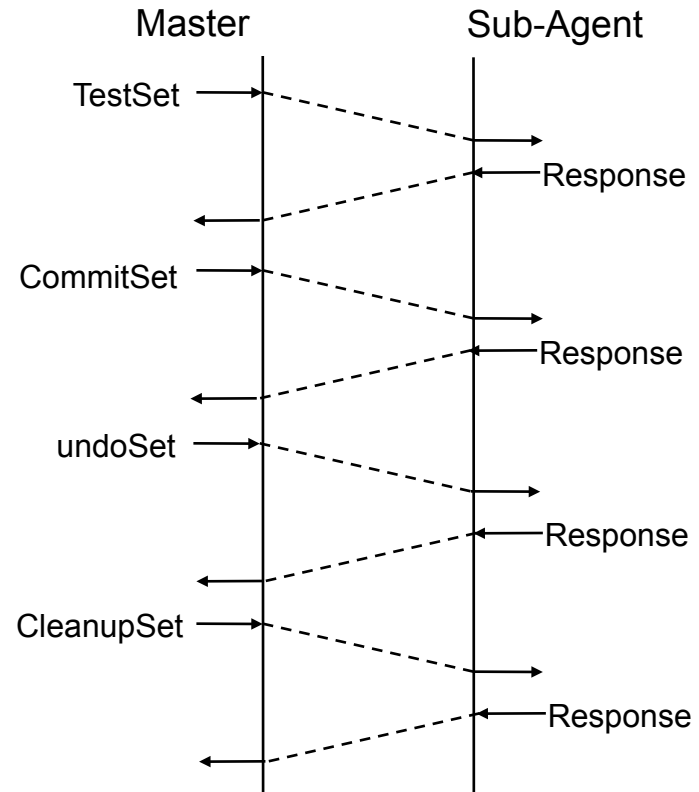
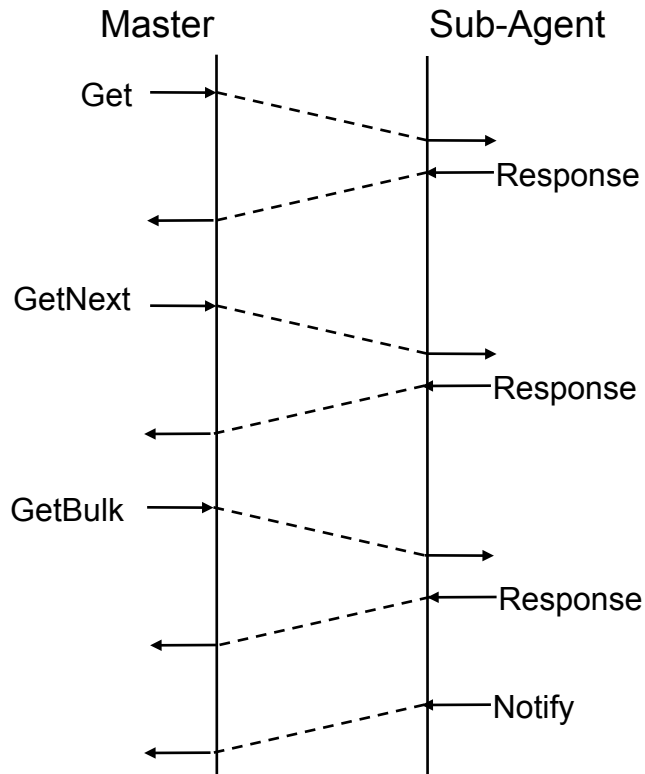

- SNMP-operations correspond to AgentX operations.
- A SNMP operation can concern several subagents.

- Atomicity of SNMP SET operations is guaranteed by the AgentX protocol.

Why did SNMP Succeed?

- ❑ Standards can be obtained for free by everybody whereas OSI standards cost money and can be distributed only to the members of the association.
- ❑ Standards are freely available from FTP/WWW servers in an electronic form whereas OSI standards are usually on printed paper and need to be ordered by plain mail to ITU that is based on Geneva.
- ❑ SNMP standards need a relatively short period of time for their standardisation. This has enabled many organisations to define new standards. OSI standards require a long time to evolve and several committee votations.
- ❑ Prototypes must demonstrate the need for and the feasibility of Internet standards. OSI standards are usually first defined on papers and finally implemented. In order to produce an RFC it is required to release two or more independent implementation of the standard in order to prove standard's feasibility.

Example of Free SNMP Implementations

- ❑ NET-SNMP: <http://net-snmp.sourceforge.net/>
- ❑ Scotty: <http://wwwhome.cs.utwente.nl/~schoenw/scotty/>
- ❑ JMAPI: <http://java.sun.com/products/JavaManagement/>
- ❑ Advent: <http://www.adventnet.com/>